



Longacre®

Racing Products

2015



finish line

RACING PRODUCTS
Williams Lake, BC
1-800-734-3805

www.finishline.ca

Coil Spring Testers.....20	Scale Ramp System26
COMPUTERSCALES™11-19	Scale Setup Fixture.....22-23
Cornerweight Scales.....11-19	Scale Systems.....11-19
Gas Can Weigher.....18	Scales, High Capacity.....19
Kart Scales.....16	SideSliders™22
Kart Setup Fixture16	Slip Plates22
Laser Level18	Spring Rubbers20
Platen23	Turn Plates27
RC Car Scales.....19	Valve Spring Tester.....20
RC Car Durometer19	Wireless Scales12-14
Roll-Off Levelers.....24-25	
Scale Carts.....18	
Scale Laser Level18	
Scale Pad Specs11	
Scale Pad Box18	



CHASSIS SETUP EQUIPMENT

A-Arm Spacers.....30	Chassis Height Checkers...34	Stagger Tools35	Toe-In Gauges.....32
Bump Steer Gauge35	Digital Caster Camber28-29	Stagger Tape.....32	Toe Plates.....33
Caster Camber Gauges28-31	Digital Level29	Tire Roll Out.....32	
C/C Gauge Adaptors.....30	Kart Camber Gauge.....28, 30	Tire Scribes32	



TIRE MANAGEMENT

Air Tank w. Filler Gauge...36
Digital Tire Gauges.....38-40
Durometers45
Filler Tire Gauges41
IR Pyrometers.....46
Laser Pyrometers.....46
Memory Tire Pyrometers ..47
Paint Pen (tire).....36
Pyrometers.....46-47
Tire Hardness Testers.....45
Tire Marking Sticks36
Tire Pressure Gauges.....37-43
Tire Pyrometers.....46-47
Tire Pyrometer Probes47
TIRELIEFS™44
Tread Depth Gauges45
Valve Core Tools.....36
Valve Stems, Tools.....36



Adel Clamps60	Switch Panels55-56	Weather Pack Connectors..60
Battery Cable & Parts.....60	Tachs49	Weatherproof Switches59
Battery Disconnects59	Tach Panels48-50, 52	Wiring Harness – Panels ..54
Battery Jumper Posts.....59	Warning Lights – Engine...61	
Brake Balance Gauges54		
Dash Panels48-53, 57		
Data Logging Tach49		
Digital Tach49		
Electric Fuel Pump Shutoff..61		
GAGELITES™61		
Gauges48-53, 57		
Gauge Lines50, 54		
Gauge Panels.....49-53, 57		
Ignition Switches58-59		
Stepper Motor Gauges48-49, 52-53		
Stepper Motor Tachs.....48		
Switches.....58-59		



SPECIALTY TOOLS

AccuLevel™64	Lug Nut Sockets65
Air Density Gauges62	Oil Filter Cutter.....62
Coil Over Wrench.....62	Pit Impact Gun65
Cordless Impact Guns65	Plumb Bobs64
Digital Caliper.....64	Safety Wire Pliers & Wire..64
Digital Level64	Shock Inflators63
Gloves (pit gloves).....64	Sockets (lug nut)65
Impact Gun65	Track Mats62
Leakdown Tester (engine) ..63	



STEERING WHEELS

HD Steering Nose Pad.....68
Nose Pad.....68
Steering Wheels66-67
Steering Quick Disc.68



MISCELLANEOUS TOOLS

Air Cleaner Studs75	Fuel Line.....76	Longacre Gear78	Throttle Linkage Kit75
Bolt-On Accessories.....72-73 (drink holder, radio box, etc)	Header Bolts76	Magnetic Drain Plugs76	Throttle Return Kits75
Brake Balance Adjusters...74	Header Insulation.....78	Mirrors.....73	Throttle Stop Brackets.....75
Brake Lines, Kits, Fittings ..74	Header Ins. Ties – SS.....78	Rear End Breathers.....73	Timing Systems.....69
Brake Bleeder Bottles74	Helmet Hooks72	Roll Bar Padding70-71	Tire Temp Charts69
Car Covers79	Hood Pin Kits77	Shifter Knobs & Arms.....77	Trailer Hitch Bumpers70
Cases (misc)79	Hot Lap™ Timers.....69	Spark Plug Viewer76	
Clipboards (w. Stopwatches)..69	Hydraulic Clutch Lines76	Spoiler Supports.....77	
Comp. Tester (engine)76	Insulation78	Stopwatch Clipboards69	
Door Bar Padding70-71	Lap & Chassis Charts.....69	Stopwatches.....69	
Firebraided Insulation78	Lexan Cleaner & Polish.....78		
Floor Mats.....78			

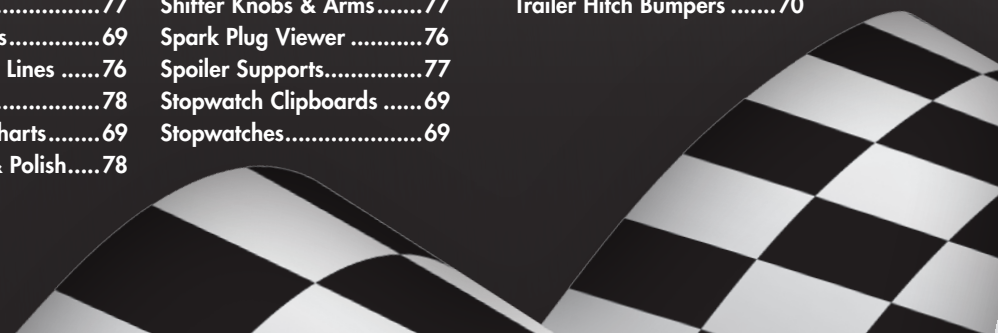

Meet Our Management Team



Jack Jaynes – PRESIDENT

Jack is the founder of Longacre Racing and has been developing products for the racing industry for over 40 years, beginning with the building of complete engines for many prominent racing teams. Today he oversees Longacre's operations and works on future new products with the talented staff.



Tom Glibhero –
VICE PRESIDENT OF SALES

Tom has a long history of involvement in auto racing as an open wheel driver and as a track promoter. Tom currently heads up the sales division and is also involved in our social media program and video production.



Tobey Butler –
LOGISTICS AND PURCHASING MANAGER

Tobey, a former NASCAR® NW Series champion, drove three years in the NASCAR® Craftsman Truck Series. He makes sure we have all the thousands of components we need daily.



Gary Lewis – SALES FLOOR LEAD

Gary is a long standing Longacre team member. His experience with Longacre spans over manufacturing, testing and sales for over 17 years. His 25 years of hands-on racing experience is a tremendous value, and he knows exactly what parts it takes to run up front.



Michael Gawthorp –
INSIDE SALES

Michael has more than twenty years' experience in the automotive-tire service industry. His role is to provide customer service to our network of dealers across the United States.



Chris Cunningham –
DEALER LIAISON

Chris started racing at 10 and has raced everything from Go Karts to Late Models to Sports Cars and won championships along the way. On weekends he serves as Director of Competition at Evergreen Speedway.



Misty Greel –
CUSTOMER SERVICE MANAGER

With Longacre since 2002, Misty has worked in accounting and international sales, and presently manages the Customer Service and Repair department. We are excited to bring Misty onto our management team here at Longacre.



Karla Alexander – CONTROLLER

Karla has more than 20 years of Accounting and Management experience across many industries. Her responsibilities include our accounting and human resource departments. She has been with Longacre since 2000.



Mike Aubrey –
MACHINE SHOP MANAGER

Mike comes from a background in tool and die design and manufacturing. He brings a wealth of knowledge to help us produce quality parts. He keeps our CNC machining department humming.



Shelby Williams –
PRODUCTION SCHEDULING

Shelby has been with us for many years in the accounting department. Recently she made a move to the production scheduling department and makes sure we are building the right parts in the right quantities to keep the shelves stocked.



Elizabeth Haddon –
GRAPHIC DESIGN LEAD

Elizabeth designs all our print material from our catalog to ads and monthly flyers. Her design skills are also utilized to help create the graphics for many of our products. She also bears a striking resemblance to a popular NASCAR® Sprint Cup® driver.



Matt DeLaVergne –
PRODUCTION MANAGER

Matt oversees all our in-house production and is involved in quality control also. He stays busy keeping the staff building the parts you need and also works on improving production efficiency to keep costs as low as possible.

***All Our Products Are Designed,
Assembled, And Tested Right Here In
Our Factory In Monroe, WA***



Turn to pages 6 – 9 for our latest innovations – new products to help you run your best.

hot new products

NEW 'Bump Stop' Spring Rater

Special High Volume Pump Speeds Tests

Billet aluminum for rigidity and accurate readings.

Comes with unloader attachment to remove/install very soft springs.

- Rate bump stops, set preload
- Change springs and keep ride heights and wheel weights
- Test coilovers assemblies or just the springs
- Digital force to 1lb. and travel readouts to .001"

see pg 21

#73501 3500 lb. capacity by 1 lb.
\$1595.00

#73504 Optional wheel kit for 73501
\$54.95

#73508 5000 lb. capacity by 1 lb.
(includes wheel kit)
\$1849.00

#73509 Extra shock unloader collars
\$32.95

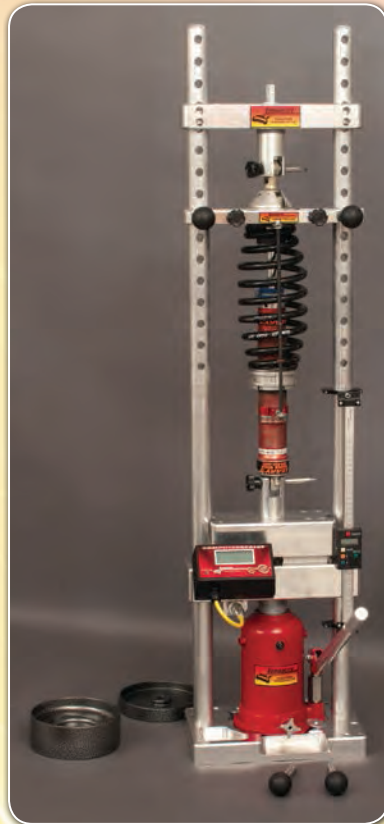

New Design Spoiler Supports

- Lightweight T6 aluminum tube w. R & L threads
- Can also be used for windshield supports
- 6", 8", & 10" in polished silver and black anodized tubes

#23756 6" Black..... **\$19.95**

#23757 6" Polished **\$19.95**

#23758 8" Black **\$19.95**

#23759 8" Polished **\$19.95**

#23760 10" Black **\$20.95**

#23761 10" Polished .. **\$20.95**

see pg 77

see pg 18

Rolling Storage Case For Wireless Scales

- Wireless scale pads have electronics and should be protected
- Store the tablet or display in the top with room for other tools too – tire gauge & pyrometer, stopwatch, etc.



#72294..... **\$289.00**



see pg 33



NEW in 2015 – magnets hold tapes in place as you work. Easier to use.

- New - Standard Toe-In Plates W. Magnets

- Quickest and simplest way to measure toe-in
- Rest one of these plates against the tire on each side and measure toe directly using the 2 tapes included
- Formed design is rigid for accuracy and stays put against the tire

#79501 **\$59.95 pair**

New Chassis Ht. Checker - Use W. Cars On Scale Pads

- Starts measuring at 2 1/2" (height of most scale pads)
- Gives you the actual chassis height once the car is off the scales. No subtraction needed here.

#78319 **\$45.95**



see pg 18



New 15" Professional Wheel W. Suede Wrapped Rim

see pg 67

- Genuine suede is the ideal surface for steering wheel rims – it gives excellent grip and comfort with less hand and wrist strain
- Same style as used by many NASCAR® teams

#56800 **\$149.90**

hot new products

"Breakthru In Scale Design"

New **COMPUTERSCALES® XLi** On A 7" Tablet

Wireless Convenience

Direct from the pads to the tablet.
No extra boxes or re-transmitters
needed here.

- 7" full color display - **Tablet included**
- Shows all partial weights & %s
- Shows Memory with current weights

From **\$1895.00** (incl. Tablet)

Coming SOON: Scales that use your
Android® SmartPhone as the control box.



See
pg 13



12" Wireless Tablet Scales

- Same specs as above but w. 12" pads in 2 capacities - 1100 lb/wheel for smaller cars and formula road race AND 400 lb/wheel for karts, legends, Banderlos, etc.

#72630 400 lb.....\$1798.00

#72691 1100 lb\$1798.00



See
pg 16



Chassis Scales For RC Cars

Set up your chassis just like professional racers do.

- CNC machined billet aluminum pads - 14 lb. capacity ea. - 3.0" x 5.5" for 1/4 to 1/10th scale cars
- Read wheel weights in .1 oz or grams - easily switched
- Shows 4 wheel weights and all partial %s - Rear, Left, Cross, Total, etc. (weight and % of total)
- 1/10 of 1% accuracy

#79985 **\$798.00**

RC Car Setup Board W. Scales Built In

See
pg 19

- Same scale system as above
- Setup board has leveling feet for accurate setups
- Scale pad tops are level with the top of the board for setting chassis heights

#79990..... **\$998.00**

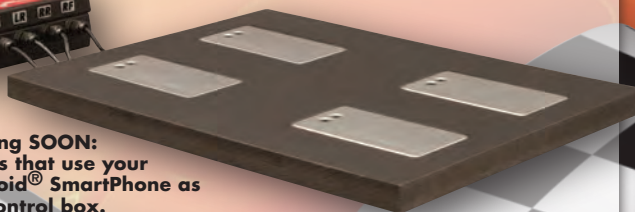

Coming SOON:
Scales that use your
Android® SmartPhone as
the control box.

Laser Scale Pad Leveler

New model



See
pg 18

If you don't level your scale pads your
'accurate setup' goes out the window!

#72977 **\$84.90**

This easy-to-use system helps you level each pad, then helps you bring all four at the same height - to closer than 0.50".

Uses a high-sensitivity machinist leveling vial.



hot new products

New Black Aluminum Switch Panels

HD 40 amp switches, HD start buttons, high temp silicone insulated wire with soldered terminals. Pre-wired and ready to install.

Many of these new switch panels come w. both red flip-up ignition switch covers and black silicone rubber weatherproof covers.

Choose the one you prefer!



Start/ign. Panel

#44861 \$33.90

See pg 55

Start/ign. Panel W. Flip-Up Safety Cover & Pilot Light

#44863 \$43.90

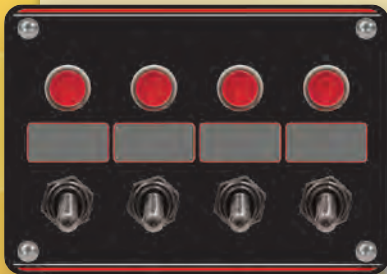

Panel W. 4 Accessory Switches & Pilot Lights

#44865 \$54.90

Start/ign. Panel W. Flip-Up Safety Cover, 2 Accessory Switches & Pilot Lights

#44867 \$65.90



Start/ign./Master Disconnect Panel W. Flip-Up Safety Cover & Pilot Light

#44871 \$91.90

Start/ign. Panel W. Flip-Up Safety Cover, 4 Accessory Switches & Pilot Lights

#44869 \$84.90



Sprint Car Panel (Designed To Stay W. Motor)

- Ultra lightweight weather resistant aluminum gauges and genuine carbon fiber panel
- Includes mag kill switch and low oil pressure warning lite (9 volt battery powered)
- Mounts from engine side of firewall, attach with Dzus fasteners – OR – permanently mount

#44423
\$198.00

See pg 54



Battery Disconnect Panel

#45760 Switch 2 Post..... \$33.50

#45784 Switch 4 Post Altn..... \$34.50

hot new products

New Black Aluminum Gauge Panels



SPORTSMAN™ Mechanical Gauge Panels W. SMi™ Stepper Motor Memory Tachs

- New graphics on gauges – Pre wired, ready to install
- Maximum RPM recall – Just push the Recall button
- Warning light on all gauges – Helps save expensive motors



#44440 2 gauge – OP, WT, Tach..... \$252.95
 #44441 3 gauge – OP, WT, OT, Tach \$303.95

#44443 3 gauge – OP, WT, FP, Tach \$303.95
 #44445 4 gauge – OP, WT, OT, FP, Tach... \$359.95

See pg 50 & 51

SPORTSMAN™ Gauges W. Black Aluminum Panels

#44430 2 gauge – OP, WT \$102.95
 #44431 3 gauge – OP, WT, OT \$158.95
 #44433 3 gauge – OP, WT, FP \$158.95
 #44435 4 gauge – OP, WT, OT, FP \$203.95



SMi™ Stepper Motor Gauges W. Memory Tachs In Black Aluminum Panels

- All gauges and tachs have multi-stage built-in warning lites – easily set by user
- Electronic sensors mount on motor – no fuel or hot oil in driver's compartment
- Pre-wired, includes all sensors, ready to install
- All gauges and tachs are LED back lit for best viewability



See pg 52 & 53



#44470 2 gauge – OP, WT, Tach..... \$424.90
 #44471 3 gauge – OP, WT, OT, Tach \$525.90

#44473 3 gauge – OP, WT, FP-15 PSI, Tach..... \$545.90
 #44475 4 gauge – OP, WT, OT, FP-15 PSI, Tach..... \$619.90



SMi™ Stepper Motor Gauge Panels



#44460 2 gauge – OP, WT \$244.90
 #44461 3 gauge – OP, WT, OT \$345.90
 #44463 3 gauge – OP, WT, FP-15 PSI..... \$375.90
 #44465 3 gauge – OP, WT, FP-100 PSI..... \$375.90
 #44467 4 gauge – OP, WT, OT, FP-15 PSI... \$479.90

Checkout our NEW Website!

www.longacracing.com

800.423.3110

GET AHEAD OF THE PACK

HOME ABOUT US DEALER LOCATOR TECH LIBRARY CATALOG REQUEST HELP DEALER LOGIN CONTACT CART

PRODUCTS

- COMPUTER SCALES®
- SCALE LEVELING & ACC.
- CASTER CAMBER GAUGES
- CHASSIS SETUP EQUIPMENT
- TIRE PRESSURE GAUGES
- PYROMETERS
- DUROMETERS & TREAD DEPTH GAUGE / TACH PANELS
- GAUGES & TACHS
- GAGELITES™ / SENDERS & ACC
- SWITCH PANELS
- SWITCHES & ELECTRICAL
- PIT EQUIP, SPECIALTY TOOLS
- BOLT-ON PARTS & MIRRORS
- TIMING PRODUCTS
- STEERING WHEELS & HUBS
- ROLL BAR PADDING
- ENGINE TUNING TOOLS
- BRAKE PARTS
- CAR COVERS
- INSULATION PRODUCTS
- MISC PARTS & TOOLS
- LONGACRE GEAR & GIFTS
- NEW PRODUCTS

Industry Innovator

One of the leading creators of racing products for more than 20 years.



[LEARN MORE](#)

Select your category. No matter which way you roll, we've got what you need.

Essential Tools

Stock Car

Modified

Road Racing

Drag Racing

Open Wheel

RC Car

Kart

FIND A DEALER

Our coast-to-coast dealership connections will provide you with fast and friendly delivery of the Longacre product line.



[LOCATE](#)

VIDEOS

See our products in action with our library of video tech tips, product instructions and general information.



[LEARN MORE](#)

TECH LIBRARY

Have a question about your chassis, brakes, etc? We have an extensive collection of tech articles to help you attain your personal best.



[LEARN MORE](#)



SAVE BIG \$ ON PARTS

Get first-hand news about new products, tech info

Full Name

Email Address

[SUBSCRIBE TODAY](#)



[REQUEST A CATALOG](#)

Tablet Scales

Wireless convenience and advanced features on a tablet. The future of racing scales is here.



Gauge Panels

Check out our stunning Accufach SH™ line of gauges. Tough, accurate, and beautifully backlit.



Caster-Camber

Go with a digital version for incredible accuracy. Serious teams will love a gauge that reads to one-tenth of a percent.



Tire Gauges

Longacre has an expansive selection of digital, analog and liquid-filled gauges.



Tire Pyrometers

Racers, store up to ten complete sets of tire temps with our deluxe digital pyrometer model.



Steering Wheels

We've got aluminum or steel, smooth, fat grip, bump grip, dished, drilled and even suede.



Switch Panels

Colorful aluminum switch panels with Aircraft-style Flip-up safety switch covers.



Bump Steer

New design gauge with universal billet plate and single precision dial indicator.





© 2002-2014 Longacre Racing.
Monroe, WA 98272 | Phone: 800.423.3110

ABOUT US

DEALER LOCATOR

United States

International

RC Dealers

Become a Dealer

CATALOG REQUEST

TECH LIBRARY

Videos

Technical Articles

Instructions

CONTACT

HELP

FAQs

Warranty and Repair

Shipping Policy

Return Policy

Privacy Policy

DEALER LOGIN

CART

[f](#) [t](#) [v](#) [y](#)

Visit Us On Facebook!



Online Catalog

- Everything you need to know about Longacre products: photos, detailed product descriptions, instructions and tech tips

Tech Articles

- Helpful tech information on a variety of racing topics

Dealer Locator

- Need help finding a Longacre part? Use our Online Dealer Locator to find a distributor near you.



Rigid Low Deflection Pads Give You The Most Accurate Setups Possible.

A quick comparison

Longacre® scale pads have elaborate computer designed internal strengthening ribs for maximum rigidity. This minimizes pad deflection and gives you the most accurate, consistent readings possible with a single cell pad. Without these strengthening ribs the pad would flex excessively and affect your weights. This same engineering principle is why bead rolled or folded sheet metal is much more rigid than flat.

On the other hand

Some brands with so called "billet" pads are simply 1/2" thick flat aluminum plates. They look nice but without strengthening ribs they do not have the needed rigidity to give you the most accurate readings, especially if the wheels are not perfectly centered on the pads or if you run high camber. And they are heavy – 23 lbs. vs. 15 lbs. for **Longacre's** pads.

True billet pads start with much thicker material for rigidity. The excess is then machined away to save weight, leaving strengthening ribs in the critical areas. This makes for very good pads – but they are extremely expensive – \$3000 and up – and are actually no more rigid than **Longacre®** pads!

Be sure you know what you are looking at and understand the engineering.

For the lowest deflection

Longacre® Dual Load Cell pads give you the lowest deflection of all. The design allows the dispersal of stress over a much larger area of the pad to minimize platform deflection. You get the least deflection and the most accurate and consistent setups possible at a reasonable cost price.

Pad deflection for these tests were measured at the edge of the pads using an 800 lb. test weight. Tests were run both with weight centered and offset by 4" to simulate camber.



Longacre®
Single Cell Pad



Typical deflection:

Wheel centered	.018"
Wheel offset	.094"
Pad weight	15 lbs.



sheet metal shield

1/2" thick plates

Typical "billet" pad from some manufacturers – 2 flat plates and a single load cell

Without strengthening ribs these pads will actually flex more. The sheet metal shield between the upper and lower plates has no structural function.



Typical deflection:

Wheel centered	.025"
Wheel offset	.130"
Pad weight	23 lbs.

Longacre®
Dual Cell Pad



Typical deflection:

Wheel centered	.007"
Wheel offset	.017"
Pad weight	23 lbs.

Advantages Of Tablet Scales



Current weights and Memory weights

are shown at the same time for easy comparison. Makes hitting your target setup simple and hassle free.



The tablet is enclosed in a protective folio that also serves as a stand. We also included a Silver case for the ultimate protection as well as a screen protector and stylus.

Other Exclusive Tablet Scale Features

- An easy-to-use Setup Page lets you customize the partial % display if you wish. (Change to Metric readout here if needed.)
- Battery condition for pads & tablet is shown on the display.
- There is a special high contrast screen for very bright sunlight conditions.
- Tablet automatically works in both horizontal ('landscape') & vertical ('portrait') orientation.
- Recharger for tablet is included. Pads use replaceable AA Alkaline batteries.

Car icon and all weights can be rotated on the display for easiest viewing from any position around the car. Just tap the button on the top of the car.

Best when standing behind the car.

Best when standing on the right side of the car.



Best when standing in front of the car.

Best when standing on the left side of the car.



Custom Car Icon

For the car icon on the display you can choose a stock car, modified, Indy/F1, or a kart. You can even have a picture of YOUR car as the icon to personalize your system.

Compare Our Pads To Others

Other mfg. 'billet' pads

Longacre pads

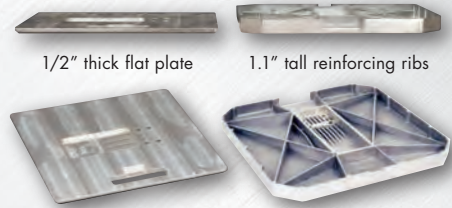

1/2" thick flat plate

1.1" tall reinforcing ribs

Our pads use elaborate computer-designed reinforcing ribs to add rigidity that's not available with simple flat plate style 'billet' pads. The more rigid your pad is the more accurate your setup.

COMPUTERSCALES® dxi™



2014 model wireless scales available while supply lasts.

- Fully CNC machined pads – dead flat – within .005" with built-in Wireless transmitters
- A compact control box with Wireless receiver
- 8 slot easy-access Memory

#72711 w. single load cell pads\$1995.00
 #72725 w. DUAL load cell CNC pads\$2995.00



Simple to use, just turn it on.

Shows all 4 wheels & all partial % plus an 8 slot Memory

Keeping 'Tabs' On Your Setup

New COMPUTERSCALES[®] XLI On A 7" Tablet (tablet included)

Full color high resolution display.

All set up, ready to use right out of the box.

(Shown with Billet Levelers and Turnplate Roll-offs – available separately – see pages 24 & 25)

Really easy to use.

No computer experience needed here. Turn it on and go.



WIRELESS convenience.

The cables are gone, nothing to trip over.

From the pads directly to the tablet.

No extra boxes needed here. Convenient, no clutter.

- Shows ALL partial weights & %s
- Shows Memory with current weights
- Wheel weights and car icon can be rotated on the display – easy view from any position

#72715 15" x 15" x 2½" SINGLE Cell Pads

\$1895.00 incl. TABLET

#72726 15" x 15" x 2½" DUAL Cell Pads

\$2895.00 incl. TABLET

#72691 12" x 12" 1100 lb. Pads

\$1798.00 incl. TABLET

actual picture

SCALES & ACCESSORIES

Basic Wireless Model



AccuSet II™ Wireless Scales

- 4 line display shows all weights and partial %.
- Satin finished pads with single load cells, internally CNC machined for parallel, 15" x 15" x 2½", 1500 lb/pad capacity.
- Baseline Memory Recall for comparison to current weights.

Easy to use!

Simple controls, uncluttered display.



All 4 wheel weights plus Cross.

AccuSet II™ control box in a Silver case Wireless pads – set up, ready to use.

#72702..... **\$1595.00**

Wireless modules are enclosed inside the pad to prevent damage. No external antenna to get broken, no fragile modules outside the pad.

Push one button and get all your partial weights and %s.



COMPUTERSCALES® dxi™ Professional Models

These 2 Pro models have CNC pads & Premium HD yellow cables



Model 1:
With **SINGLE** Load Cells

Model 2:
Fully CNC Machined
Low Deflection Pads With
DUAL Load Cells



Switches easily

NEW pads have internal strengthening ribs for rigidity (see page 11). The electronics show all 4 wheel weights on separated displays plus a 4 line display that gives you all partial weights and % at the same time. This can be easily customized to your preference, line by line. Display just what you want, nothing you don't. No information overload here. (see close-up below).

- Easy-to-use 8 slot Memory
- HD Yellow cables, Billet AN connectors w. locking nuts & gold plated contacts

Model 1: Traditional SINGLE load cell pads with internal strengthening ribs#72609 w. SINGLE load cell pads..... \$1445.00

Model 2: DUAL load cell pads, which give you a more rigid platform with less deflection.....#72652 w. DUAL load cell pads.....\$2195.00

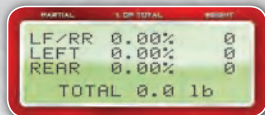

Customize each line individually.
display just what you want - nothing you don't.

These scales use the latest low power electronics. They run on replaceable batteries that can last a full season. No recharger needed.

Semi-Pro Wired Model

With Satin Finished Pads And Red Hi-Flex Poly Cables

COMPUTERSCALES® dxi™

Satin finished pads are flat to within .010" and have internal webs to minimize deflection for accurate setups.



A nice step up from basic models - at a great price

- Shows all 4 wheel weights on separated displays.
- Also shows ALL partial weights and % at the same time.
- High quality Red HiFlex Poly cables with Billet AN connectors.
- Deluxe Silver carrying case protects electronics & stores cables.

A great system for seasoned teams or first year.

#72601 **\$1198.00**

You can easily customize the 4 line display to your preference, line by line. Choose just what YOU want - Left, Right, Front, Rear, Cross, "Bite", Total, etc. No cluttered display here.

SCALES & ACCESSORIES

Scales For Lighter Cars And Karting



These Systems Come With 12" x 12" Pads (400 Or 1100 lb. Capacity)

Great for IMCA cars, Legends, Dwarf, Mini Cup, Bandeleros, Karts, Road Racing Formula classes, Quads, etc.

Basic Model Karting Scales



Switches easily

- 4 line display shows all 4 wheels and ALL partial %
- CNC machined dead flat low deflection pads for the best accuracy – 400 lb. capacity
- Easy to use – just set them up and turn them on
- 1/10% accuracy • 2-year limited warranty
- Silver carrying case and heavy duty Red Poly cables

#72624 w. 12" CNC pads..... **\$998.00**



New COMPUTERSCALES® XLi On A 7" Tablet

Direct from the 12" pads to the tablet.

• See pages 12 & 13 for tablet details

#72630 400 lb..... \$1798.00

#72691 1100 lb..... \$1798.00



Billet Aluminum Kart Setup Fixture

- Optimum rigidity for accurate setups
- Light weight with detachable legs for compact storage
- Can be used w. other size kart pads (call factory)

#72961 for 12" CNC kart pads..... **\$549.00**

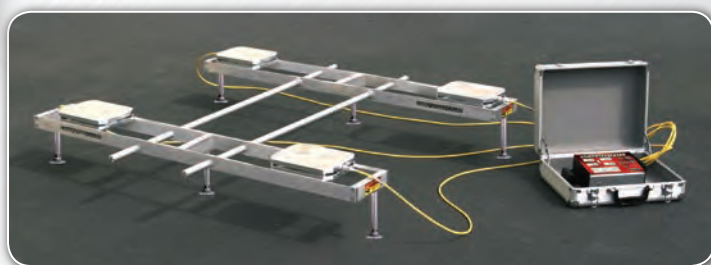

COMPUTERSCALES®

- Display shows all 4 wheel weights plus all %
- 12" x 12" x 1100 lb. capacity powder coated pads

#72582..... **\$998.00**



To Protect Your Pads

(They have electronics inside) we strongly recommend our optional pad storage box.

#72280 12" Pad storage box..... **\$185.00**

Basic System with Satin Finished Scale Pads

Pads are flat to within .010". Elaborate internal webs to minimize scale pad flex for more accurate setups.

COMPUTERSCALES® AccuSet II™

Easy to Use - just push a button to get everything you need.

Simple, uncluttered display - just the information you want, nothing you don't.



NEW - Baseline Memory Recall

Store your baseline setup in Memory. Then recall it instantly to compare to the current setup. Saves time writing it down - always handy. **This 1 slot memory is really helpful and is super easy to use. No complicated operations here.**

- Shows all 4 wheel weights plus Cross Weight
- Push one button for all partial % & wts.
- Face is slanted - easier viewing
- New Heavy-duty Red HiFlex Poly cables & Billet AN connectors
- Includes deluxe Silver carrying case for electronics & cables
- Low profile pads with Satin Finish - **flat to within .010"** - for accurate setups
- 15" x 15" x 2½", 1500 lb/pad capacity

#72593.....**\$1049.00**

ALL Partial %



4 wheel weights plus Cross.



OR



Optional partial % display (incl. Front & Right).

Optional wheel weight display (incl. Total).



Push ONE button to get either display - instantly

SCALES & ACCESSORIES

Laser Scale Pad Leveler

New model

If you don't level your scale pads your 'accurate setup' goes out the window!

#72977 **\$84.90**

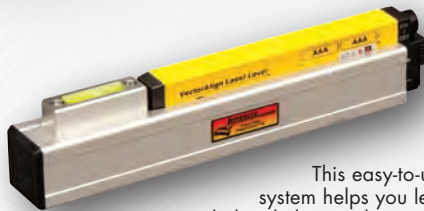

This easy-to-use system helps you level each pad, then helps you bring all four at the same height – to closer than 0.50".

Uses a high-sensitivity machinist leveling vial (NOT the hardware store type)



Easy to use:

First use the level vial to accurately level all four individual scale pads. Next turn the laser on, put it on top of one pad (this is your baseline pad) and point it at another one. Put the measuring tab on this pad and slide it sideways until one of the white dots shows brightest in the laser beam. That dot is marked how much higher or lower it is than the baseline pad. Raise or lower that pad until the dot at **Level** shows brightest. Do the same for the other two pads and you have a precisely leveled surface for the most accurate setups possible.



Scale Pad Storage Boxes

- Padded lining keeps pads protected
- Heavy duty aluminum frame with scuff-resistant sides
- Could also be used for radios or other equipment

#72292... **\$199.95** (for 4 - 15"x15" low profile pads)

#72280..... **\$185.00** (for 4 - 12"x12" kart pads)



Handy Scale Cart

- Convenient storage at the track or in the shop
- Cart holds the control box at just the right height
- Rolls around the shop and pits with ease
- Pads slide in on a steep angle – easier to get in and out, won't come out in transit
- Durable powder coated finish



#72304..... **\$379.00**
(comes assembled – just bolt on handle & wheels)



Rolling Storage Case For Wireless Scales

Handle retracts when not needed

- Wireless scale pads have electronics and should be protected
- Store the tablet or display in the top with room for other tools too – tire gauge & pyrometer, stopwatch, etc.

#72294..... **\$289.00**



New Chassis Ht. Checker - Use W. Cars On Scale Pads

- Starts measuring at 2-1/2" (height of most scale pads)
- Gives you the actual chassis height once the car is off the scales. No subtraction needed here.

#78319 **\$45.95**

(Not for use w. levelers or roll-offs or w. car is not on scales. See page 34 for other Chassis Height Gauges)



Gas Can Weigher

- Reads to 1/10 lb.
- Weigh gas can during a pit stop to determine fuel mileage
- 12" x 12" platform
- 350 lb cap.

#72330..... **\$749.00**



Higher Capacity Systems 3500 Lbs./Pad 14,000 Lbs. Total



These are special high capacity systems – also great for Pull-Down Rigs. 4" tall pads
Call the factory for more details.

#72663
 3500 lb. Powder coated pads
\$3495.00

- 15" x 15" x 4" tall HD pads, powder coated
- AA Battery powered
- lb. or kgm
- Control box shows 4 individual wheel weights plus partial %
- Extra long 24' HD Yellow cables w. lock ring connectors

Scales For RC Cars *See Page 29 For A New Digital Caster Camber Gauge*



Chassis Scales For RC Cars

Set up your chassis just like professional racers do.

- CNC machined billet aluminum pads – 12 lb. capacity – 3.0" x 5.5"
- Read wheel weights in .1 oz or grams – easily switched
- Shows 4 wheel weights and all partial %s – Rear, Left, Cross, Total, etc. (weight and % of total)
- 1/10 of 1% accuracy
- 2-year limited warranty
- Silver carrying case for pads and electronic box

#79985 w. NEW 3.0" x 5.5"
 CNC pads **\$798.00**



Getting your chassis set up correctly and accurately will make a huge difference in handling and give you more wins and better finishes.



Durometer For RC Car Tires

RC car tires are much softer than full size car tires. This special durometer is calibrated to read RC tires correctly. Easy to use, quick and accurate.

#79980
 Durometer w. red case **\$59.95**



Coming SOON:
 Scales that use your Android® SmartPhone as the control box.

RC Setup Board W. Scales

- Set you car up accurately and easily
- Scale pads are built into the board – flush w. the top
- Same scales as above – see specs
- Available soon: Wireless RC scales with a 7" tablet – OR – use your SmartPhone as control box

#79990..... **\$998.00**

SCALES & ACCESSORIES



Billet Aluminum Electronic Coil Spring Tester

- 0 - 3000 lbs. by 1 lb.
- Travel to .001"
- 6" to 20" tall springs
- Coil and coil-over springs – square end and 'pigtail'
- Includes easy-to-use digital indicator to measure travel and digital load readout

#73505..... \$995.00



220 charger available also



Wide Range Billet Aluminum Coil Spring Tester

- Similar to tester on page 21 but with more range, up to 36" overall and 20" travel.
- 3500 lb force by 1 lb. and 20" travel to .001".

#73507..... \$1998.00

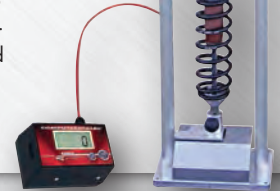

Digital Electronic Valve Spring Tester

- Spring pressure from 0 to 1400 lbs. by 1 lb. increments
- Spring travel from 0.000" to 4.000" in .001" increments
- 1/10th of 1% accuracy – on both spring pressure and travel
- Positive stop to make repeated spring checks at the same height
- Check springs with or without retainer
- Spring travel and pressure can be zeroed at any point
- Quick and easy to use
- Runs on battery or 110 volt (220 v available)

#73511

Digital electronic valve spring tester
\$1049.00

#73512

Digital electronic valve spring tester to 600 lbs or 400 lbs by .1 lb
\$1098.00

A NEW HD rigid design like a machine tool for more accurate readings makes this is the best valve spring tester available!



Digital spring travel

Coming soon: 2 new models – one for larger springs to 3500 lb., one for very low rate springs.

Large Spacing Spring Rubbers

These days, many front running teams are using the new style coil-over springs that have fewer coils and wider spacing, giving more spring travel before you coil bind.

With these new spring rubbers, you can now fill that larger gap between coils to fine tune your set-up.

- #61016 orange – soft \$36.95
- #61041 red – medium \$36.95
- #61051 blue – hard \$36.95



1-1/4" thick

Spring Rubbers

3/4" thick (coilover) 1-1/4" thick (5/5.5")

- Fine tune your spring rate for the perfect setup
- Make quick adjustments during practice or on pit stops
- Used by virtually all Sprint Cup™ teams in every race

- #61005 Coil Over Spring Rubber Yellow 5 Soft..... \$36.95
- #61010 Coil Over Spring Rubber Clear 10 \$36.95
- #61015 Coil Over Spring Rubber Orange 15 \$36.95
- #61040 Coil Over Spring Rubber Red 40 \$36.95
- #61050 Coil Over Spring Rubber Blue 50 \$36.95
- #61070 Coil Over Spring Rubber Black 70 Hard \$36.95
- #61140 5/5.5" Deep Groove Spring Rubber Red Soft \$49.95
- #61150 5/5.5" Deep Groove Spring Rubber Blue Med..... \$49.95
- #61170 5/5.5" Deep Groove Spring Rubber Black Hard \$49.95



NEW 'Bump Stop' Spring Rater

Special High Volume Pump Speeds Tests

Billet aluminum for rigidity and accurate readings.

Comes with unloader attachment to remove/install very soft springs.

- Rate bump stops, set preload
- Change springs and keep ride heights and wheel weights
- Test coilovers or just the springs
- Digital force and travel readouts

#73501
3500 lb. capacity by 1 lb.
\$1595.00

#73504 Optional wheel kit
\$54.95

#73508
5000 lb. capacity by 1 lb.
(includes wheel kit)
\$1849.00

#73509 Extra shock unloader collars (2 incl. w. rater)
\$32.95

New Features Included:



SHOCK PINS ARE MODIFIED TO LET YOU EASILY AND ACCURATELY MEASURE SHOCK CENTER-TO-CENTER DISTANCE, RIGHT ON THE TESTER.

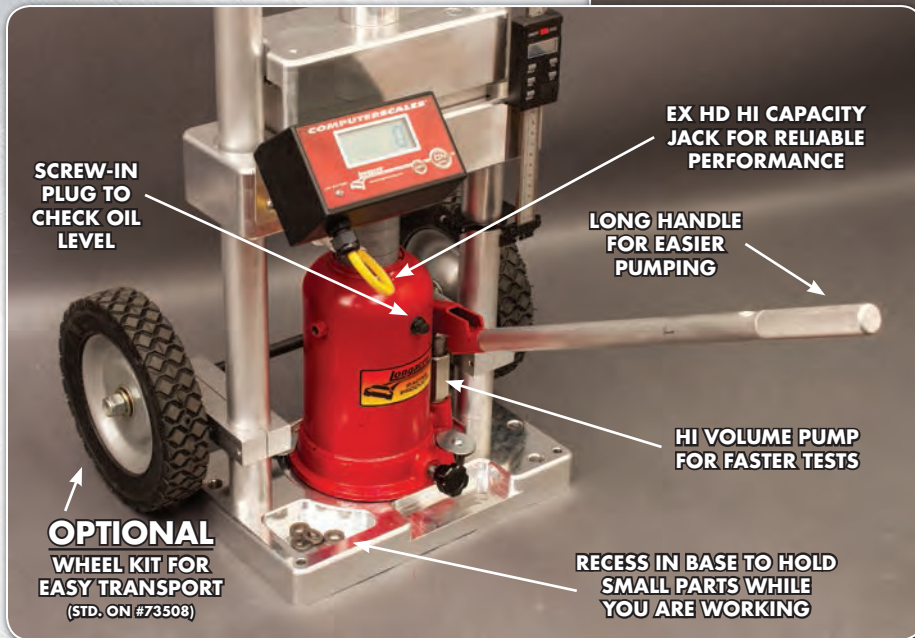
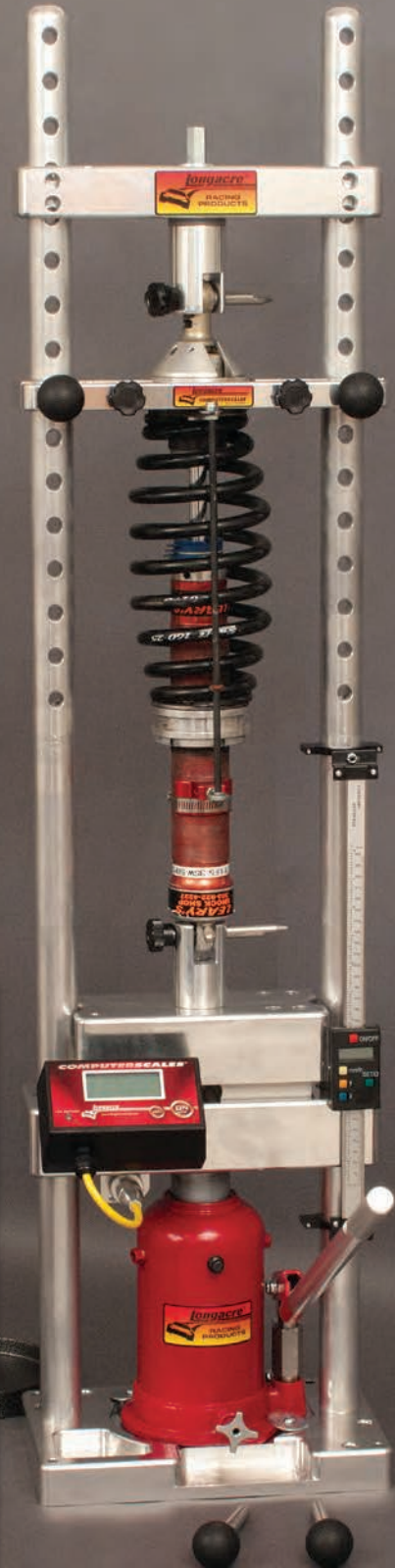

SCREW-IN PLUG TO CHECK OIL LEVEL

EX HD HI CAPACITY JACK FOR RELIABLE PERFORMANCE

LONG HANDLE FOR EASIER PUMPING

HI VOLUME PUMP FOR FASTER TESTS

OPTIONAL WHEEL KIT FOR EASY TRANSPORT (STD. ON #73508)

RECESS IN BASE TO HOLD SMALL PARTS WHILE YOU ARE WORKING

SideSlider™ For Bind-Free Setups

Chassis Roller Slip Plate

You use ball bearing A frames pivots, low friction ball joints, greaseable heim joints, and even ceramic bearings – all to eliminate suspension friction. Don't set up your car with even a small bind at the scale pads.

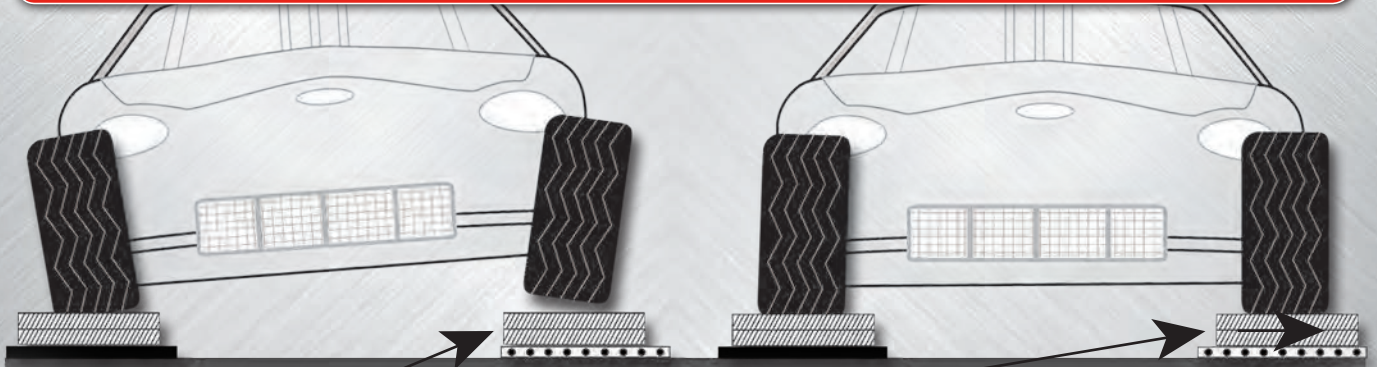

See How The LF Pad Slides Sideways, Relieving Camber Bind

When you lift your car to put it on scales the front wheels camber in at the bottom. As you let it down the wheels must be allowed to freely camber back out or there will be a small residual bind in the chassis. This will make your wheel weights (and your setups) less than perfect. To avoid this the front wheels must be able to easily move sideways.

With **SideSlider™** your front wheels can move sideways effortlessly to relieve any camber-induced bind. This will assure you the most accurate, consistent setups possible.

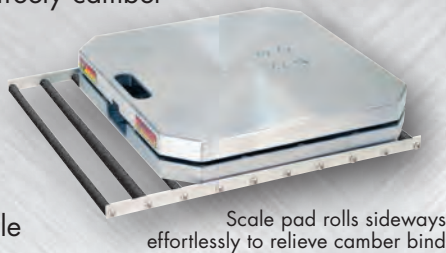

Scale pad rolls sideways effortlessly to relieve camber bind

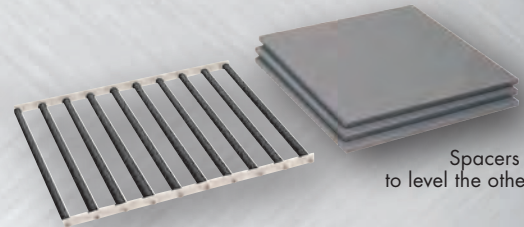

Spacers included to level the other 3 pads

- Rollers are made from a tough, low friction polymer
- Install under Left Front wheel (it has the most camber change)
- 3 spacers are included to re-level your setup
- Use on any smooth floor surface

#72870 1 **SideSlider™** & 3 spacers..... \$94.95

#72872 2 **SideSliders™** & 2 spacers..... \$159.95
(for cars w. independent rear suspensions)

Greased plates? These are simply 2 pieces of sheet metal w. grease or Teflon™ between to minimize side bind. And they work reasonably well. But when there is a load on them they don't relieve **all** the lateral load and they leave you with some chassis bind. Rollers, on the other hand, will move virtually friction-free, **regardless of the load**, and eliminate ALL the side bind for the most accurate chassis setups possible.

What happens to your wheel weights when you turn the front wheels?

Find out!

"3D" Ball Roller SideSliders™

A Different Kind Of SideSlider™
3 Way Slip Plates For Bind-Free Setups With Wheels Turned

These **SideSliders™** move in 3 directions – sideways, front & back, **and they rotate**. They are great for checking wheel weights with wheels turned. See what happens to your wheel weights w. different caster settings.

- Install under both Front wheels
- MUST BE USED UNDER SCALE PADS
- Supported on ball bearings made from a low friction polymer
- 2 spacers are included to re-level your setup
- Use on any smooth floor surface

#72875 "3D" Ball Roller SideSliders™ (2 plates and 2 spacers)..... \$298.00

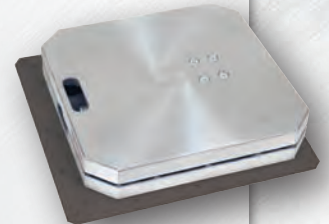

BILLET ALUMINUM MODULAR SETUP PLATEN:

Best rigidity for accurate setups.

Scale pad levelers are CNC machined from T6 aluminum billet with a full floor for best pad support.

- **Easy to assemble**
- **Easy to transport**

Modular components assemble quickly, then break down for efficient transportation.

Ships by UPS® or FedEx®



INCLUDES:

- Four Billet Scale Pad Levelers with Pop-Out feet (24 total)
- Two adjustable spanners
- Two ramps
- Two horizontal locator bars



Assembles in 15 minutes or less – and disassembles even quicker.

- Billet T6 aluminum scale pad levelers w. a full floor for the best rigidity & the most accurate setups.
- Swivel adjusting feet pop out for quick and easy storage.
- Spanners are attached to levelers and are flush w. the top of scale pad.
- For 15" x 15" x 2.5" scale pads, wired or wireless.

#72860..... **\$2495.00**
Fully adjustable for wheelbase (90" – 110") and track width.



OPTIONAL VERSION:

SideSliders™ (see left) allow the pads to float effortlessly sideways to relieve any chassis bind caused by camber change. Great for IRS cars.

#72865..... **\$2795.00**
Complete platen w. **2 SideSliders™** – LF & LR

#72862..... **\$2675.00**
Complete platen w. **1 SideSlider™** – LF only

This new setup platen uses the best design, engineering, and fabrication. The Billet aluminum scale pad levelers are rigid for accurate setups and the formed spanners and ramps are strong, yet lightweight. Just set up the Billet levelers and clip on the spanners & ramps.

OPTIONAL TURNPLATE ROLL-OFF



Set caster & camber right on the platen. These attach quickly and easily to the front levelers and come w. Pop-out adjusting feet.

#72856.... **\$498.00** set of 2 (turnplates not incl.)
#79800 Turnplates..... **\$698.00** set of 2 (see pg 27)

OPTIONAL FRONT ROLL-OFF

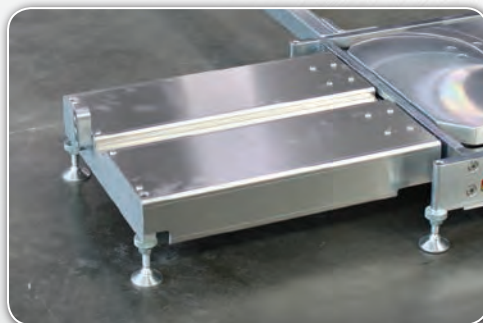

They allow your car to roll forward off the scale pads. Come w. 2 Pop-out leveling feet. Set of 2.

#72851 18" **\$279.00/pair**
#72853 30" **\$298.00/pair**

Add to your Platen's functionality with these special purpose Roll-offs.

New Style Scale Pad Leveling Fixtures

Modular Billet Levelers

Use alone or w. optional Roll-offs.

(see below and right – page 25)

Sets up quickly and disassembles easily for convenient storage and transportation.

Rather than the traditional one-piece bulky roll-off, these units are modular. The actual scale pad Leveler is made from T6 billet aluminum with a full floor for the best rigidity and the most accurate setups possible. The optional roll-offs attach quickly to these Levelers via a simple clip-on bracket. All 4 Levelers & roll-offs set up in less than two minutes (plus leveling time). The Leveler has four swivel adjusting feet that pop in and out for convenience and easy storage. The roll-off has two more pop-out feet.

The advantage to this Modular Billet Leveler system is you have multiple options: Get just the Billet Levelers, 18" or 30" Roll-offs (roll-off area on most 1 piece Roll-offs are 14" or less; often that's not enough), and even a special Roll-off for turn plates so you can set caster & camber at the same time (see page 25). Roll-offs can also be bolted solid on if desired.

And this modular style system is much less bulky to store and transport. The roll-offs detach quickly and the adjusting feet pop out to

leave a compact assembly that can be easily stored in the shop or in the trailer or pit wagon. One piece roll-off levelers are bulky to store and the feet need to be unscrewed (there are 24 of them!) so they stack properly. And you can't readily add on to them later as your needs change.

You can start with just the Levelers, then add roll-offs later. Or you can start with the entire system – Levelers, roll-offs, and turn plate fixtures.

Modular design gives you added flexibility



Billet leveler

+



Optional Roll-off attaches easily



=



Modular Roll-off assembly

#72840 for 2 1/2" pads
\$1295.00 set of 4

See multiple Roll-off options at below and right – page 25.

Also see SideSlider™ version page 25.

CNC machined T6 aluminum

Transports easily – ships

UPS® or FedEx®



(shown w. scale pad – not incl.)

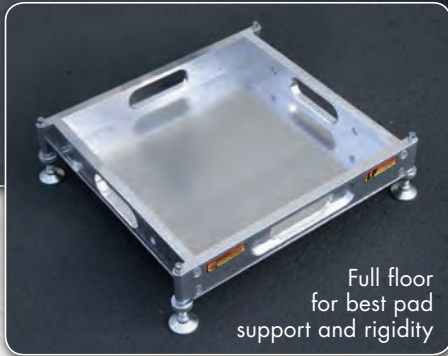

Full floor for best pad support and rigidity



Leveling feet "pop in and out" for easy setup and storage. They're held in place with "Rare Earth" magnets.

Optional Roll-Offs For Billet Leveler (see above)

Roll-offs only – quickly attach to Billet Levelers, incl. 2 pop-out feet (can be bolted together solid if desired)



18" roll-off
#72850

18" roll-offs shown w. Billet Levelers (not incl.)
#72850 18" \$495.00 set of 4



30" roll-off
#72852

30" roll-offs – shown w. Billet Levelers (not incl.)
#72852 30" \$549.00 set of 4

Billet roll-offs are also available on special order. (not shown)
#72850 & #72852 above are formed aluminum. Contact factory for details.

New Style Scale Pad Leveling Accessories

**SAVE \$95 w. Package Deal:
Billet Levelers & Roll-Off**

Billet Scale Pad Levelers Plus 18" Roll-Offs - Package Deal!

#72830 for 2 1/2" pads..... \$1649.00 set of 4
(separate prices \$1790)

Roll-offs can be 'clipped on' modular style or bolted solidly in place.



Most one-piece roll-off fixtures only have 12" to 14" of roll-off area. Sometimes that's not quite enough (think Martinsville). If you start with low tire pressures the 'contact patch' can be long.

Roll-Offs For Turnplates

Set your caster and camber right on the fixture

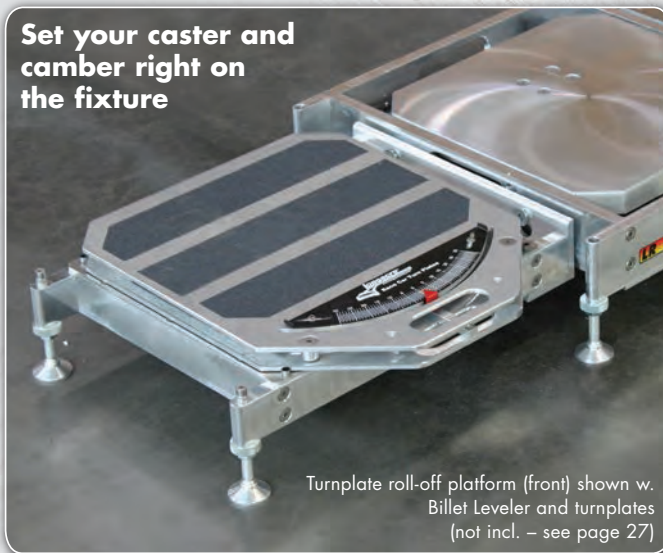

Turnplate roll-off platform (front) shown w. Billet Leveler and turnplates (not incl. - see page 27)

Roll-offs for turnplates - attach to front of levelers - includes 2 pop-out leveling feet for convenient storage (Billet pad levelers not incl.)

#72856..... \$498.00 set of 2 (turnplates not incl. - see page 27)

To roll forward onto turnplates you will also need 2 roll-offs at the rear (if you don't already have them - see small picture below).

#72851 (2 only) 18" roll-offs w. leveling feet.....\$279.00

Some Options - Tailor It To Your Needs. Add On Any Time.



Billet Leveler
Use by itself.



OR

Billet Leveler + Roll-off
Rear only or front and rear.

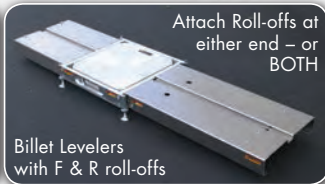

Billet Levelers with F & R roll-offs

Attach Roll-offs at either end - or BOTH

AND/OR



Optional turnplate Roll-off set caster & camber

Billet Leveler + Roll-off + Turnplate Roll-off



Billet Levelers w. SideSlider™

See page 22 for SideSlider™ details

#72842 Billet Levelers w. 1 SideSlider™ in LF set of 4.....\$1398.00

#72844 Billet Levelers w. 2 SideSliders™ in LF & LR set of 4 ..\$1499.00 (for cars w. independent rear suspension)

To relieve camber-induced chassis bind - for the most accurate setups

Same specs as on page 24, incl. Pop-out feet

Formed Roll-off Levelers



Roll car off scale pads, then back on again to settle chassis.

- Rigid formed and welded aluminum construction
- 6 HD swivel feet for easy leveling on most any surface (not pop-out style)
- Wheel stops on 2 roll-offs for safety

#72905 for 2 1/2" scale pads\$998.00 Set of 4

Roll-Offs With Built-In SideSlider™

Formed & welded aluminum – specs above

#72912 Set of 4 roll-offs w. SideSlider™ in LF .. \$1249.00

#72922 4 roll-offs w. 2 SideSliders™ in LF & LR ..\$1398.00
(great for cars w. independent rear suspension)



See page 22 for SideSlider™ details



Individual Scale Pad Levelers

- For a quick, accurate setup anywhere
- 4 HD swivel feet (not pop-out style)
- Lightweight formed & welded aluminum
- w. or w/o SideSlider™

#72900 for 15" pads (12" pads also) – set of 4.....\$498.00

#72913 for 15" pads w. SideSlider™ in LF – set of 4 ..\$698.00
(not shown)

New Ramps – 36" Long

to get your car on the scales easier
(most other ramps are only 15" long)

- 36" long, car rolls up on scales much easier than shorter ramps, **quicker than using a jack**
- Formed aluminum, strong, lightweight, durable
- Set of 4, for 2 1/2" scale pads

#72537 set of 4..... **\$398.00**

These 36" long ramps give you an angle of 3.9° to make getting you car on easier. Shorter low cost ramps have a much steeper incline – as much as 7.8°.

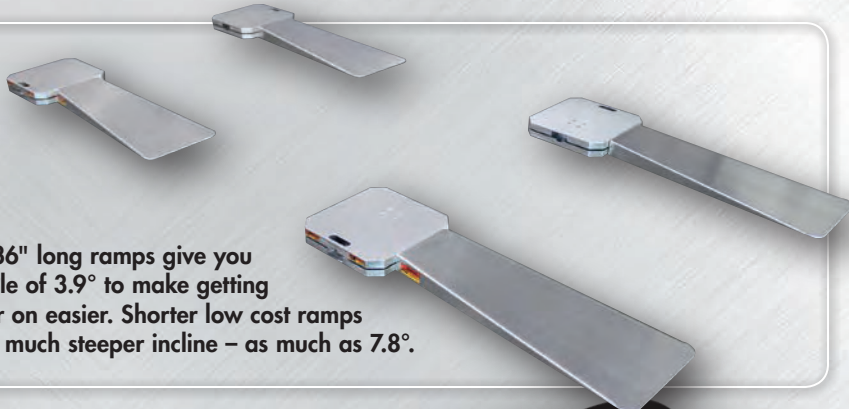



Aluminum Turn Plates

- Low profile, only 1" tall
- Reads to 1/2° - Degrees can be zeroed with the car on
- Free floating in 2 directions eliminates bind
- Can be used on top of scale pads

- #79800 Aluminum turn plates (pair)..... **\$698.00**
- #79805 Set of 1 **\$429.00**
- #79751 Rear spacers w. slip plates (pair)..... **\$109.95**
(To level rear of car when using turnplates on ground)



Budget Roll-Offs

- Low cost way to roll your car off your scales, then back on again
- For 2 1/2" pads on ground

- #72904..... **\$188.90** Set of 4
(not for turnplates)

Screw-In Swivel Feet

Pack of 2 (not pop-out) 1/2" - 13 thread

- #72894 4"..... **\$30.95** Pack of 2
- #72890 8"..... **\$74.95** Pack of 2

Pop-Out Feet

Pack of 2 Pop-Out replacement swivel feet (ONLY for roll-offs designed for pop-out feet)

- #72896 4"..... **\$39.95** Pack of 2
- #72893 8"..... **\$84.95** Pack of 2

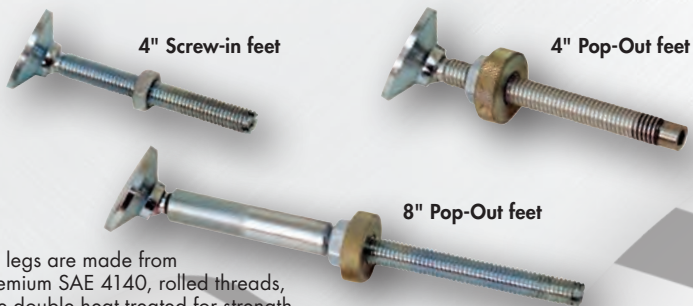

8" legs are made from Premium SAE 4140, rolled threads, are double heat treated for strength.



Billet aluminum fully CNC machined. Rigid for accurate readings.

Three-leg design squares gauge to your wheel.

Pointers on this model are designed for formed wheels. The tip goes inside the bead of the wheel and centers the gauge.

QuickSet™ Digital Caster/Gamber Gauge

- Reads to .1° • Will work on most any car
- **AccuLevel™** digital readout can be easily removed and used for other angle measurements on the car. Can compensate for unlevel ground – more accurate readings
- Just hold it against the rim to make a measurement – no adapter needed

#78295 Digital C/C gauge w. **AccuLevel™** and **QuickSet™** adapter w. case – reads to .1° camber **\$289.90**
(for wheels 12" to 17" – see NEW model below for larger wheels)



Comes with Silver case



This is the fastest way to check your front end alignment, just hold it against the rim for easy, accurate readings. No spindle adapters required here.

Made from CNC machined billet aluminum. Works on most race cars, to 17" wheel.

Three-point design squares up to your wheel, folds up for easy storage.

Uses most caster camber gauges.

#78428 QuickSet™ adapter only – use your gauge... **\$114.90**
(for 12" to 17" wheels)



Folds up for easy storage

New Model For Large Wheels

Up to 22" aluminum wheels, adapts to bead, folds for storage, similar to #78428 above

#78430 QuickSet LW™ adapter only – use your gauge... **\$129.00**

Pointers on this model are designed for cast aluminum wheels. A lip goes over the bead of the wheel and centers the gauge.

NEW Model For Large Wheels

From 17" to 22" aluminum wheels, 'feet' adapt to wheel bead, folds for storage, similar to #78295 above

Digital C/C gauge w. **AccuLevel™** and **QuickSet LW™** with Silver case – reads to .1°

#78298 **\$299.90**



Comes with Silver case

Quick-Set Caster Gamber Gauge W. Billet Vial Style Gauge

- No adapter needed, just hold it against the wheel
- Reads camber +/- 9°, caster + 12° to -4°
- For wheels 13" to 17"

#78274 **\$239.90**



Digital KART Caster/Gamber Gauge

- Reads to .1° – as high as needed
- Comes with special kart screw-on spindle adapter

#78110 Billet Kart digital caster camber gauge..... **\$179.95**

Digital Caster/Camber Gauges



Great for bump stop cars w. high LF camber. Reads as high as you need.

AccuLevel™ easily removes from gauge and can be used for other measurements such as spoiler and A frame angles, suspension and driveline, etc.



Digital Caster Camber

Here's a super accurate digital caster/camber gauge that reads to .1° (1/10°) and at a price any serious team can easily justify. It comes with our latest Super Magnetic adapter and a padded Silver carrying case.

Caster reads directly – no math to do like some other low cost gauges. There is a backlight for dark areas and a **Hold** feature for hard-to-reach places. This is really a must-have tool for any serious race team.

- #78290 Caster/Camber w. Magnetic adapter... **\$229.90**
- #78291 Caster/Camber less adapter **\$184.90**
- #78292 Caster/Camber w. kart adapter.. **\$199.90**



Comes with Silver case



AccuLevel™ Digital Level Pro Model

- Back light for dark places under car
- Measure suspension and spoiler angles, lots more
- Simple to use, easy to read, accurate
- Reads to .1° (1/10°) – from 0 to 90°
- HOLD feature for hard-to-get places

#78311 **AccuLevel™** Pro Model digital level **\$119.90**

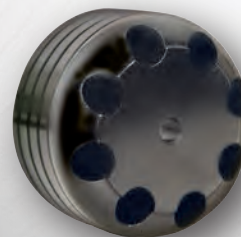

"Rare Earth" magnets installed from the back

NEW: Billet Magnetic adapter w. 8 premium "Rare Earth" magnets – installed from the back for protection. Flush face, easy to clean.

Coming Soon – Digital Caster Camber Gauge For RC Cars

• Caster and camber settings are just as important to RC cars as to full size cars. Set yours accurately and easily with this new gauge.



- Reads to .1°. Hold sensor against wheel on a level surface to take the reading. Fits most RC wheels.

#78284 RC car digital C/C **\$169.90**

Caster/Camber Gauges

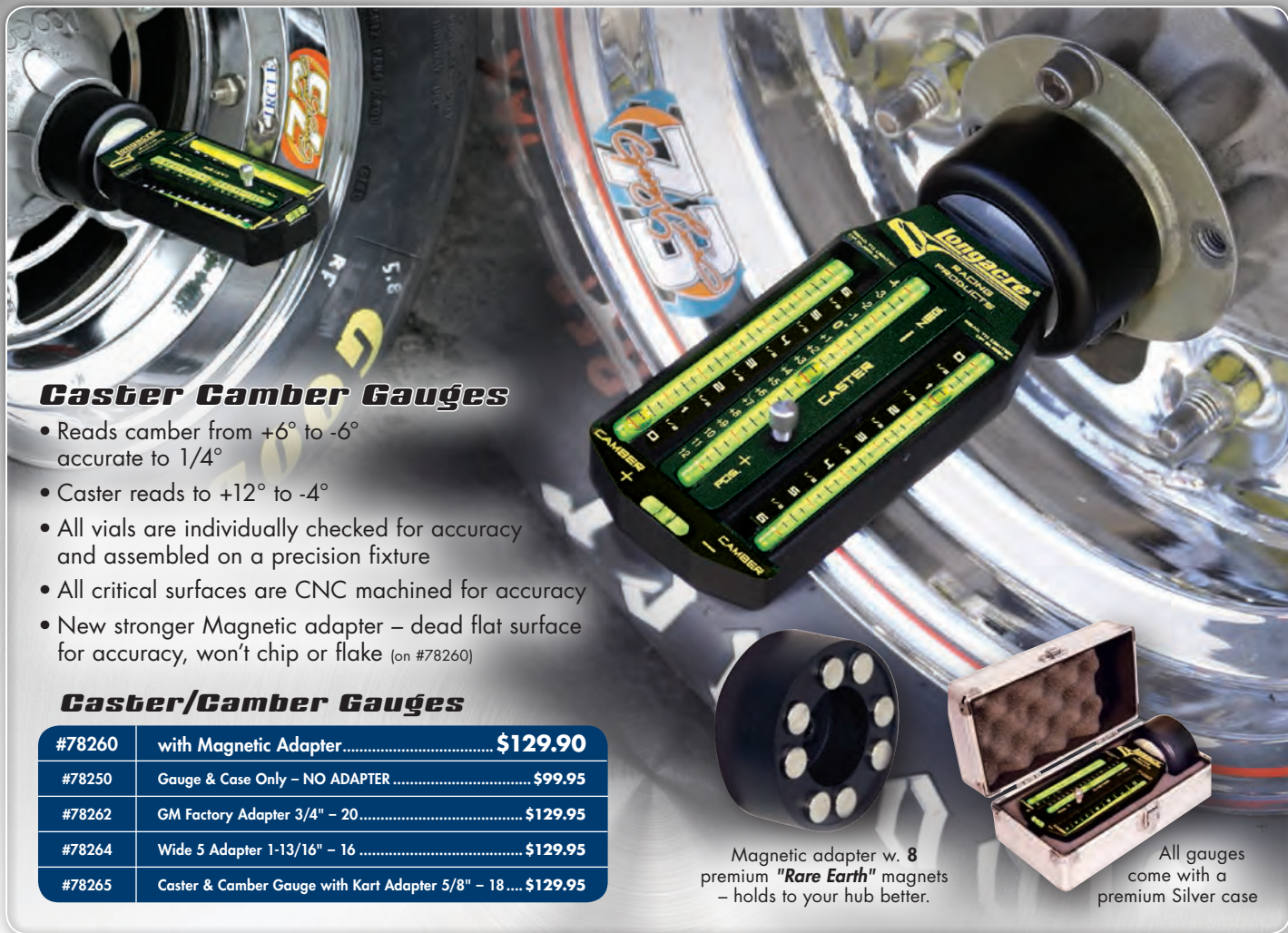

Caster Camber Gauges

- Reads camber from +6° to -6° accurate to 1/4°
- Caster reads to +12° to -4°
- All vials are individually checked for accuracy and assembled on a precision fixture
- All critical surfaces are CNC machined for accuracy
- New stronger Magnetic adapter – dead flat surface for accuracy, won't chip or flake (on #78260)

Caster/Camber Gauges

#78260	with Magnetic Adapter.....	\$129.90
#78250	Gauge & Case Only – NO ADAPTER	\$99.95
#78262	GM Factory Adapter 3/4" – 20	\$129.95
#78264	Wide 5 Adapter 1-13/16" – 16	\$129.95
#78265	Caster & Camber Gauge with Kart Adapter 5/8" – 18	\$129.95

Magnetic adapter w. 8 premium "Rare Earth" magnets – holds to your hub better.

All gauges come with a premium Silver case

Separate Adapters

#78405	Wide 5 or 5 on 5 Spindle 1-13/16" – 16	\$44.90
#78410	Factory GM 3/4" – 20.....	\$39.90
#78412	Allison Legacy / Big Ford 13/16" – 20	\$41.90
#78414	Small Ford 3/4" – 16 (also used on many road race cars)	\$41.90
#78422	Magnetic Adapter for #78260 (8 "Rare Earth" magnets)	\$69.90
#78424	Billet Magnetic Adapter – for #78272.....	\$79.95
#78428	QuickSet™ Billet Caster Camber Adapter	\$114.90
#78430	Large Wheel QuickSet™ Billet Caster Camber Adapter.....	\$129.00
#78438	Fine Go-Kart Adapter 5/8" – 18.....	\$45.10
#78439	Kart Adapter – (metric) – 14mm x 1.5	\$45.10
#78445	Legend Car – (metric) – 19 millimeters x 1.5	\$45.10

Most adapters screw onto spindle (except magnetic & QuickSet™).
New size metric & other adapters are coming out often. Call for your specific needs if not here.

Aluminum A-Arm Spacers

- Won't fall out when setting front end
- Lightweight aluminum • 6" bolt centers

#78512 Kit (all 4) **\$39.95**
1 each of 1/16", 1/8", and (2) 1/4"



Kart Camber Gauge

- Specially built for karts
- Reads ± 6° camber
- 5/8"-18 screw-on kart adapter
- Metric adapters avail. – see right

#78100 Camber gauge.... **\$124.95**



Includes Silver carrying case

Also see page 28 for Digital Kart Caster Camber Gauge.



Billet Caster/Camber Gauges

This is a professional grade tool. CNC-machined from a solid billet of T6 aluminum – polished, bright-dip anodized & laser engraved.



Comes with Silver case



- **Expanded range**

Measures camber to + or - 9° and caster + 12° to - 4°

- **Glow-in-the-Dark** vials – much easier to read even in good light
- CNC machined **Billet aluminum** – polished, BrightDip anodized, Laser etched
- **NEW Super Magnetic adapter** – stronger pull
Uses 8 premium 'Rare Earth' magnets to hold to your hub better, CNC machined for a dead flat surface and the highest accuracy possible
- Can measure caster with or without turnplates (best accuracy if used w. turnplates)

#78272 Billet Caster Camber Gauge..... **\$159.90**

#78273 Billet Caster Camber Gauge only – less adapter **\$109.90**



NEW: Billet Magnetic adapter w. 8 premium "Rare Earth" magnets – recessed for protection. Flush face, easy to clean.

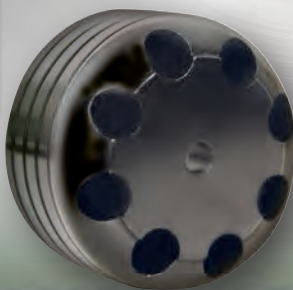

"Rare Earth" magnets installed from the back

Gody Blake
Photo By David Heath



Toe-In Bar ("Toe Bar")

Similar to our #79620 toe-in gauge below but this new model measures to the outside of the tire. No scribe line needed. Fast & easy. Reads toe to 1/16". Can be done by 1 person. Billet aluminum. Adjustable up to 88" in width – Great for wide track cars, Corvettes, etc.

#79622..... \$112.90

Small wheels on the bar let it slide under the car more easily.



Both the Toe Gauge and Toe Bar are simple to use & measure toe-in within 1/16".

Toe-In Gauge

- An accurate way to measure toe-in to within 1/32"
- Easily done by one person • See #79610 Tire Scribe

#79620..... \$108.90

To get a very accurate toe-in measurement, jack up front wheels and scribe a true running line on the face of the tire.

Place the gauge in front of the tires and align the pointers with the scribe lines. Then move the gauge to the rear of the tires and align the fixed end with the scribe line.

On the other end loosen the thumb screws and move the slider until the pointer aligns with the other line. Now read the exact toe-in on the scale.

Quick, easy, & accurate.

Modular Design = Savings for you.

These **Toe Gauges and Toe Bars** disassemble for shipping, saving you money. Some lower cost models come fully assembled and must ship at the more expensive Oversize Rate, costing you \$15 or more of additional shipping charges.

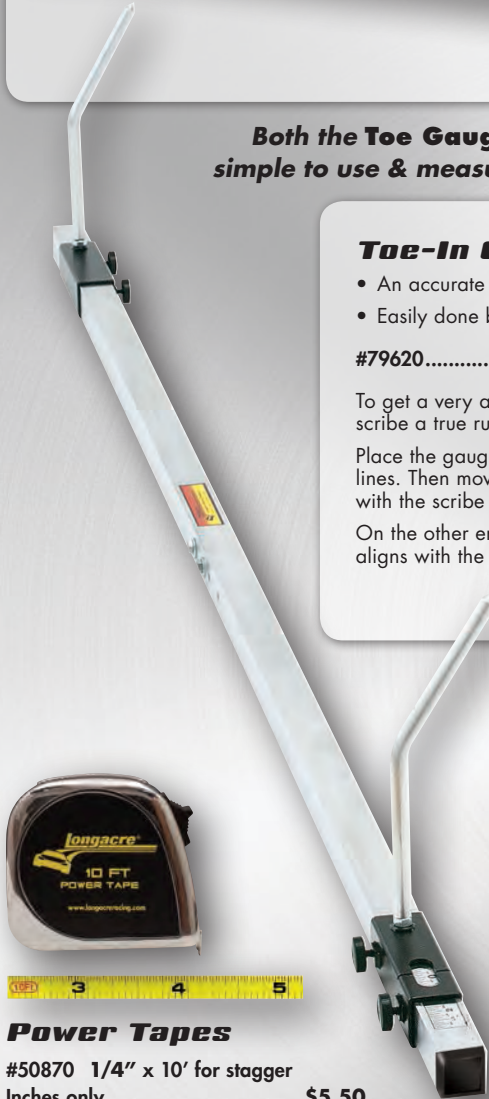

Power Tapes

#50870 1/4" x 10' for stagger Inches only..... \$5.50

#50875 3/4" x 10' for toe-in, wheelbase, etc. Inches only..... \$6.95



Folds up for easy storage

Billet Tire Scribe

- Use to make a true running line on the face of the tire for measuring toe-in
- Use w. #79260 Toe-In Gauge above left
- Spring loaded for easy one person use

#79610 \$72.95

Tire Roll Out Fixture

- Wheel spins freely – check stagger easily and accurately
- Clean or groove tires quickly
- Find leaks, punctures or tire damage fast
- Convenient design, saves you tons of time and hassle

#50853 Includes 10' Stagger Tape \$42.95

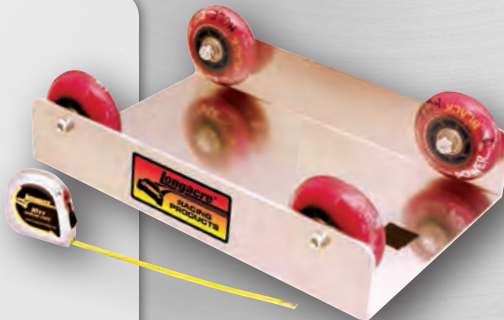

Chassis Setup Charts

- Punched for 3 ring binder • Packaged 1 pad, 50 sheets

#22528 Tire chart/Chassis setup ...\$9.95

NEW

magnets hold tapes

**Standard
Toe-In
Plates**

- Quickest and simplest way to measure toe-in
- Rest one of these plates against the tire on each side and measure toe directly using the 2 tapes included
- Formed design is rigid for accuracy and stays put against the tire (see #79505 below)

#79501 \$59.95 pair



NEW in 2015 – magnets hold tapes in place as you work. Easier to use.



**Deluxe HD
Toe-In Plates**

- Thicker material, deeper bend gives you more rigid plates for better accuracy
- Higher kick-out on bottom holds plate against the wheel better. Great for cars w. high camber LF wheels (bump stop cars)
- Magnets on one plate hold the tapes in place
- Pointer makes reading tapes easier

#79505... \$104.95 pair

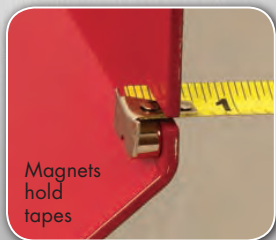

Magnets hold tapes

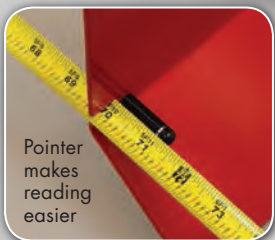

Pointer makes reading tapes easier



Great for High camber LF wheel

Attaches To Steel Wheels

Mounts on the wheel for best accuracy

Makes setting toe a quick 1 person job

- Incl. set of 2 fold-up fixtures, 2 tapes, Silver carrying case



- Similar to our NEW QuickSet™ caster camber

- Magnets in the legs hold your steel wheel – one on each side
- Eliminates tire 'bulge' error

**QuickToe™
Setting Tool**

Here's a different way to set your critical toe-in. A pair of three pointed fixtures mount to the wheels (with magnets) for super accuracy. You can even attach a caster camber gauge to either side. Use tapes included to measure toe directly.

#79630 QuickToe™ 2 adapters w. magnetic legs, 2 tapes, Silver case \$298.00

Chassis Height Measurement Tool Works In 3 Different Ways

- 1) Car on ground – measures chassis height directly, accurate to 1/16"
- 2) Car on scale pads – measures from top of pads – ground level – to frame directly (no subtracting needed here)
- 3) Measures chassis height dynamically, as you work on car. Magnet holds tape to frame. Indicator shows height *as car moves up and down*. Use set of 4 to quickly see height at all 4 corners. *You don't even need to bend over.*

NEW!

Metric scale available

- 2 lengths – 36" for straight rail cars on right side
24" for perimeter frames
- Measures height from 2" to 10" (higher if needed)
- Works 3 ways – car on ground OR with scale pads

- #78320 Short model (1) \$89.95
- #78322 Short model (set of 4)..... \$319.95
- #78324 Long model (1) \$98.95
- #78326 Set of 4 – 2 Short & 2 Long \$349.95



#78324

#78320

MINI Chassis Height Checker

Great for quick, accurate checks of chassis height. Push it under the car, raise the tape with the knob, pull it out, and read the height. Range is 2 - 8", accurate to 1/16". This is shortened and simplified version of the Chassis Height Checkers above. Quick, accurate, easy to use.

It's a great replacement for 'step' type tools, more accurate, more versatile, and easier to use.

#78318 \$37.95



New Model For Use When Car Is On Scale Pads

Starts reading at 2 1/2" (height of most scale pads). Shows what your chassis height will be when car is back on the ground. Similar to #78318 above.

#78319 \$45.95



#16 Joey Becker
#38 Jimmy Hebert
Photo By Leif Tillabson

NEW!



Both have Dual scales – on two sides.

Easy to read with tires on the car or flat on the ground.

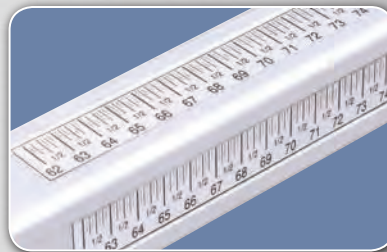

Both models use custom tight tolerance aluminum tubes for more accurate readings. No 'slop'.

Billet Aluminum Stagger Gauges – 2 Models

Standard Billet Stagger Gauge

- 3/8" thick T6 Billet arms
- 62" to 110" circumference
- Tight tolerance square tube design for accurate results
- Scale on two sides – see above – easy to read with tires on the car or flat on the ground.



#50840 w/o roller
\$66.95

Check Your Stagger Quickly And Accurately On Or Off The Car

Deluxe Billet Stagger Gauge with **ROLLER**

- Roller on one end makes measurements easier
- 3/8" thick T6 Billet aluminum arms for rigidity and more accurate readings
- Measures from 62" to 110" in 1/8" increments



#50846 with roller..... \$94.95

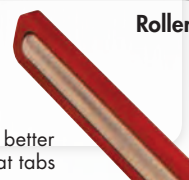

Works better than flat tabs



NEW dial indicator – easier to read shows + or - from 0.0

Bump Steer Gauge

All NEW design:

- New precision plate. 3/8" thick T6 aluminum Billet for the ultimate in accuracy. Anodized and laser engraved
- New compact frame. More rigid billet & tube design for the best accuracy. Bright dip anodized.

This simplified design uses a single indicator to tell you the exact amount of bump steer within .001". No need to subtract one dial reading from another – less chance for error.

- Most accurate, easiest and quickest way to measure your critical bump steer
- NEW extended height design – check bump steer at ride height or on stands
- NEW wheel plate has mounting holes for most 5 bolt patterns (4-1/2 to 5") and most wide 5 plus 4, 5, & 8 bolt flanges.

#79005 5 bolt/wide 5 wheel plate \$239.90

#79010 with blank plate (not billet – formed) \$229.90

For Wilwood™ Starlite™ hubs



#79121 hub mounting stand-offs \$42.95 pr.

For hubs with no mounting holes. These stand-offs screw on wheel studs (5/8" C).

Digital Bump Steer Gauge



- Similar to #79005 above, but with precision Digital readout
- Easier to use – just push **Zero**, move suspension, read bump directly to .001"
- Includes Billet plate – see above

#79015 \$269.90



Bump Steer gauge storage case #79019..... \$74.95

3/8" Thick Billet Plate



Billet Aluminum Valve Core Stem Tool



- Anodized billet aluminum with stainless steel tip
- Includes 3 spare valve cores

#50270.....\$17.95

Conveniently stores spare valve cores in the handle

Compact Valve Core Tool

- Aluminum body, steel tip
- Put on your key chain, for quick access

#50272.....\$7.25

4 Way Valve Core Repair Tool

- R & R valve cores
- Recuts damaged threads

#50274.....\$4.25

Tire Marking Stick

Writes reliably on any surface, even cold

#50880.....\$3.95

#50881 box of 12 bulk.....\$30.95



Tire Marking Pen

- Makes a finer line, easy to read
- Mark tire sizes, pressures, etc.
- Silver paint won't come off from heat

#50882.....\$7.25

#50883 box of 12 bulk.....\$67.95

Portable Ultra Lightweight Polished Air Tank

Available With Or Without Filler Tire Gauge

Special Inlet valve fills tank in less than 15 seconds

(w. adequate air supply)

Filling most tanks can take 1-1/2 minutes of precious practice time!

- All tanks include a Universal Air Quick-Change coupler – see below right

#50316 TANK ONLY (with Special Inlet Valve).....\$129.90

#50315 0-60 psi Air tank with Deluxe Quick Fill Tire Gauge (angle chuck).....\$199.90

#50311 0-60 psi Air tank with DIGITAL Quick Fill Gauge & angle chuck.....\$234.90

Available with Digital or Dial type Quick Fill Gauge



Special inlet valve fills tank much faster



Swivel Fitting

- Makes your air tools easier to use – 1/4" NPT

#36012.....\$6.95



"Ball" chuck

"Angle" style chuck

Tire Gauge Chucks

- Swivel fitting for easy use
- "Ball" chuck (usually needed for karts)
- Angled style chuck – both for 1/4" hose

#50496 Angle chuck.....\$8.95

#50494 Ball chuck.....\$8.95

Special Chuck For Small Tires - Karts, Motorcycles, Bicycles

Restricted flow for controlled filling
Helps prevent overfilling smaller tires

#50491 Restricted flow chuck.....\$8.95

#50490 Full flow filler chuck.....\$3.95

Universal Air Tool Quick Disconnect



- Connects to all 3 common fittings
- No more switching fittings to use that new or borrowed tool

#36013 pair....\$9.95

Works with all of these popular disconnects (not incl.)

All New Series Tire Gauges

Our entire tire gauge line is NEW.

Tire pressures are critical. We have the widest selection in the industry – the perfect gauge for everyone.

Plus ALL NEW gauges come with both angle and ball chucks.

- Cool new easy-to-read dial graphics
- Improved accuracy and reliability
- Digital, analog, & liquid filled
- Durable mechanisms stand up to tough racing use and maintain accuracy
- Glow-in-the-Dark dials
- **New 40 psi models**
- Wide selection of sizes & styles

Angle and ball chuck included



Magnum



- 3-1/2" face, **dual bleed buttons**, holds pressure
- 0-15, 30, & 60 psi **plus NEW 40 psi**

\$79.50
incl. Silver case

Liquid Filled



- 2-1/2" face, special valve equalizes pressure
- 0-15, 30, & 60 psi **plus NEW 45 psi**

\$52.95

Deluxe 2-1/2"



- Holds pressure, Glow-in-the-Dark face
- 0-15, 30, & 60 psi **plus NEW 40 psi**

\$45.95

Pro Digital



- Reads to .1 psi, accurate to .3%, back lite
- 0-25 & 60 psi w. **dual bleed buttons**

\$132.90
incl. Silver case

Semi Pro Digital

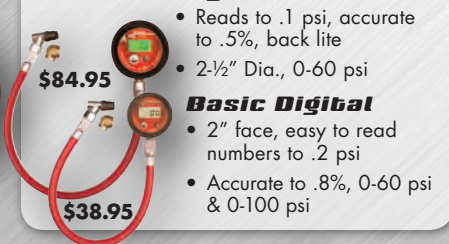

- Reads to .1 psi, accurate to .5%, back lite
- 2-1/2" Dia., 0-60 psi

\$84.95

Basic Digital

- 2" face, easy to read numbers to .2 psi
- Accurate to .8%, 0-60 psi & 0-100 psi

\$38.95

Quick Fill Gauge



- Deluxe, Liquid Filled, Magnum, or Digital

• Some with Silver case
0-60 psi
from **\$73.90**

Basic Tire Gauge



- 2" face, accurate & reliable, great value
- 0-15, 0-30 & 0-60 psi

\$26.95

Ultra Pro Digital W. Pyrometer



- Record pressures AND temps, save 4 pressures & 12 temps on display. Accurate to .1%
- Tire probe & Silver case

\$398.90

A Totally **NEW** Kind Of Tire Pressure Gauge

Comes with a rubber bumper for gauge protection.

(our competitor's Pro gauges do not!)

Setting The Most Accurate Tire Pressures:

If tire pressures are critical to your car's performance – closer than +/- 1 psi – then you really need what this gauge can do for you. Pressures must be set in the pits but the tires sitting there can easily vary by as much as 20°. You are setting on-track hot pressures by guessing (lots of experience here) at the starting cold pressure. If you want the tire to grow to 38 psi on the track you set it in the pits at say 28 psi. Sounds reasonable. You have been doing it for years.

But what was the *temperature* in the pits? If it was 80° (like it usually is) you are OK. But what if one or two had been in the sun and had crept up to 90°? For every 10° temp change there is a .8 psi change. So instead of 28 psi (at 90°) you effectively set it at 27.2 psi (what it would have been at 80° rather than 90°).

Would this make a difference? If not turn the page and look at our other gauges. If it would, (NASCAR® Cup teams fret about .2 - .3 psi) you really need to set all starting pressures at the same temperature, week in and week out. This way the on-track pressures will be the same. But how do you do that?!! You will have great difficulty controlling the temperatures (impossible really). And yet you need to.

A better way is to correct the pressures to what they would have been had you been able to keep the tires at a constant temperature. You could use a pyrometer to measure the tire's temp, then use a calculator to compute what the pressure should be at that temp rather than just putting in 28 psi. Slow and cumbersome to say the least.

But you don't have to do that. This **"Temperature Compensating Tire Pressure Gauge"** will do it for you. It can take the temperature of the tire using a traditional tire temp probe, instantly calculate the correction back to a standard temperature, and show the pressure you should be putting in the tire. It may not be the actual pressure at that moment. But it will be the correct pressure when it counts, on the track.

.1% Accuracy

US Pat. #6,983,209

Temperature Compensating Tire Pressure Gauge – To .1 psi

- Corrects tire pressures back to a standard temperature
- Displays what the pressure would be if the tire was actually at this temperature • 0-100 psi by .1 psi
- Will also function as a traditional tire pressure gauge showing **actual pressures** – all 4 stored on display
- And it will work as a precision tire pyrometer, displaying all 12 tire temps at the same time

#53050 w. Silver case.....\$398.90

#53053 gauge & case only.....\$334.90
(less probe – for tire pressure only – see page 40)

- Back lite for night use
- Accurate to .1%
- Reads to .1 psi
- 3 bleed buttons for faster adjustments

Here's how it works. Plug in the tire probe in the side of the gauge as shown. Measure the temperature the usual way – in the tread area. Push the Mode button to get to Temp Compensation. While in this Mode the pressures will be compensated and corrected back to a standard temperature (80°F). Push Mode again to go to tire temps or back to traditional tire pressures.



Shown w. tire temp probe

TRADITIONAL TIRE PRESSURE MODE:
Displays actual tire pressures.



Tire pressures stored on display

PYROMETER MODE: Ultra fast response PLUS it displays all 12 temps so you don't need to write them down as you go.



Tire temps stored on display

COMPENSATED PRESSURE MODE:
Displays what pressures would be at the standard temperature (80°F).



Pro Digital Tire Gauges

NEW improved gauge with higher accuracy and wider temp operating range

.3% accuracy
Reads to .1 psi

- Rubber bumper protects gauge
- 17" hose • Swivel chuck
- Auto - Off feature to extend battery
- Silver case included on all Pro Digital



Asphalt 0-60 psi

Easy to read - to .1 psi

Dual Bleed Buttons

#53000
w. Angle & Ball chuck
\$132.90



Angle And Ball Chuck Now Included On All 2015 Tire Gauges!

Quick Fill Digital Gauge 0-60 psi

Connect to air line
Fill & bleed with one gauge
Reads to .1 psi



#53008
w. Angle & Ball chuck \$162.90
includes Silver case
See page 41 for filler gauge details

0-125 psi

Reads - to .5 psi
(others on this page read to .1 psi)

For the hauler or trailer

#53028 w. Angle & Ball chuck ..\$132.90



Dirt LM Sprint Kart 0-25 psi

Reads to .1 psi

2 bleed buttons give faster adjustment at low pressures

Dual Bleed Buttons

#53010
w. Angle & Ball chuck \$132.90



Metric Digital Tire Gauge

Metric 0-4 bar by .01 bar

#53060 w. Angle & Ball chuck \$132.90



ULTIMATE Tire Pressure Gauge

**For Top Professionals
And Any Serious Race
Teams**

- Accurate to .1%, reads to .1 psi on large graphic display
- 0-100 psi
- Stores all 4 tire pressures on the display
- Back light for night use
- Swivel angle chuck and HiFlex hose
- 3 high volume bleed-off buttons for fast setting on pit stops

You can even connect a Longacre® tire probe to use this gauge as a pyrometer.

It has internal circuitry that measures temps and stores all 12 temps on the display – so you don't need to write them down as you go.

#53053 w. Silver case.....\$324.90



**.1%
Accuracy**



Comes with a rubber bumper for gauge protection, Hi-Flex hose for ease of use and 3-button fast air release.

(other companies 'square' Pro gauges do not include a gauge bumper and use stiff hose than can be awkward to use, specially when cold)



**.5%
Accuracy**

Semi Pro Digital Tire Gauge

- Reads to .1 psi. .5% accuracy (1/2 of 1%)
- 2 1/2" face w. larger easy-to-read numbers
- Back light for night use
- Air release button, hi-flex hose, swivel chuck

#53003 0-60 psi.....\$84.95

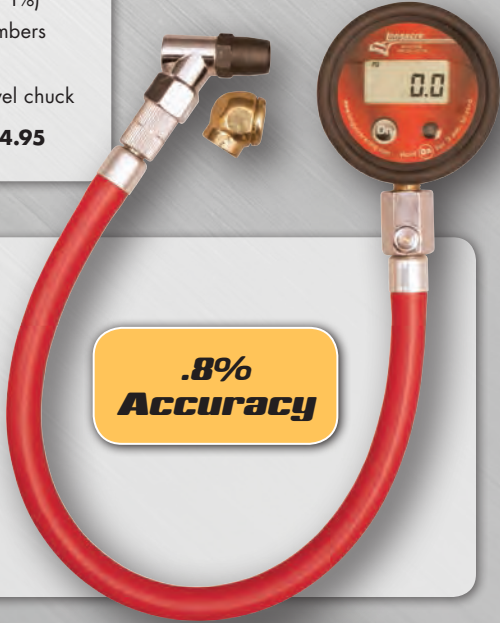

**.8%
Accuracy**

Basic Digital Tire Gauge

- 2" face w. large numbers
- Reads to .2 psi .8% accuracy
- Air release button, hi-flex hose

#53006 0-60 psi.....\$38.95

#53036 0-100 psi.....\$38.95

**Angle And Ball
Chuck Now
Included On All
2015 Tire Gauges!**



Liquid Filled Tire Gauges

At Last....A Liquid Filled Tire Gauge That Works Right!

Liquid filled gauges have many advantages. But they can change readings by as much as 2-3 psi if the temperature changes . . .

All pressure gauges – liquid filled and regular – need to be vented to the outside to read accurately. If not vented they will build up pressure inside as the surrounding temperature changes. **This will affect the accuracy** – by as much as 2 - 3 psi or even more.

But if a liquid filled gauge is vented it will leak on your hands and in your tool box. Some manufacturers aren't aware of this and don't vent their gauges. You then have to deal with the variation in accuracy.

Now from **Longacre®** comes the simple answer to this problem. We have installed a specially designed pressure equalizer knob on the top of each gauge. Before you use the gauge just loosen this knob and retighten. Instantly any temperature-caused pressure difference will be equalized and you will be guaranteed the most accurate readings possible.

15 psi gauges come with Dual Bleed buttons for faster setting



Special Equalizer Valve
Equalizes internal pressure & maintains gauge accuracy

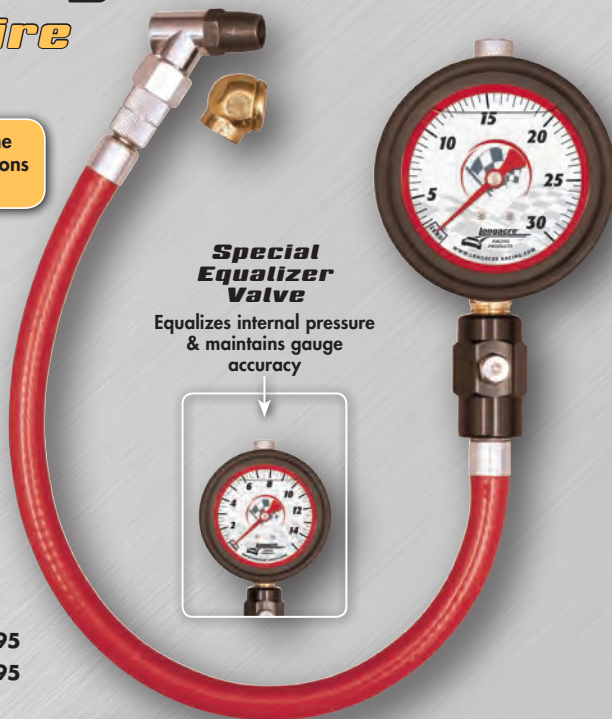

- 2-1/2 LF gauge w. bumper
- **HOLDS PRESSURE UNTIL RELEASED**
- **Glow-in-the-Dark** dial face
- 17" hose with swivel chuck

- #52002 0-60 psi by 1/2 psi.....\$52.95
- #52022 0-30 psi by 1/2 psi.....\$52.95
- #52012 0-45 psi by 1/2 psi.....\$52.95
- #52032 0-15 psi by 1/4 psi.....\$52.95 w. Dual Bleed buttons

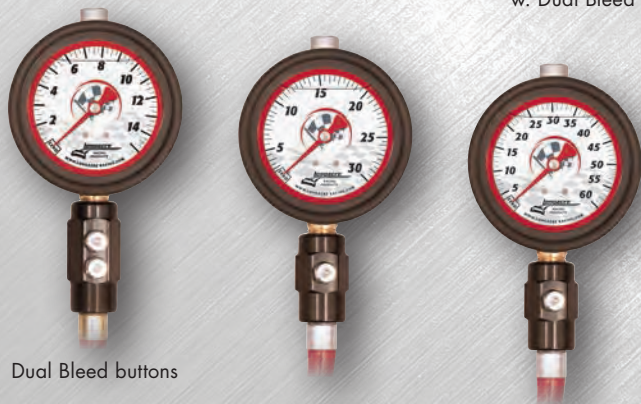

Dual Bleed buttons

NEW 45 PSI



Angle And Ball Chuck Now Included On All 2015 Tire Gauges!

Quick Fill Tire Gauge

- Connect your air line, press the lever, and fill your tires **TWICE AS FAST**
- Bleed button for excess pressure
- 4 different dial or digital gauges

- #52009 w. 2-1/2" Deluxe gauge.....\$73.90 (less Silver case)
- #52007 w. 3-1/2" Magnum gauge\$99.90 (includes Silver case)
- #52008 w. 2-1/2" Liquid filled gauge\$76.90 (less Silver case)
- #53008 w. 0-60 PRO Digital gauge.....\$162.90 (includes Silver case)



#52007 Magnum

#52009 Deluxe

#52008 Liquid Filled

#53008 Digital

Use this **MUST HAVE** tool as your regular tire gauge

Pro Precision 4 1/2" Tire Gauge



.5% Accuracy

Pro Precision 4 1/2" Tire Gauge
 The choice of the Pros!
 1/2% accuracy

- Gauge bumper
- Dual button air release
- Swivel angle chuck
- **HOLDS READING UNTIL RELEASED**

#52000 0-60 psi by 1/2 psi.....\$179.95



Includes Silver carrying case

Angle And Ball Chuck Now Included On All 2015 Tire Gauges!



0-60 psi Auto-Fill Tire Inflator Deflator

- Automatically fills tires to pre-set pressure – while you do something more important
- Also bleeds off tires at an adjustable rate
- Regulator and gauge, hose w. clip-on chuck, control valve

#50581.....\$69.95

Basic 2" Tire Gauges

- Air pressure release button
 - Internal gauge damper for more accurate readings and longer life
 - 2" dial face. 14" hose & swivel chuck
- (NOTE: Does not hold pressure)

Glow-In-The-Dark Dial Faces

- #52004 0-60 by 1 lb.....\$26.95
- #52024 0-30 by 1/2 lb.....\$26.95
- #52034 0-15 by 1/4 lb.....\$26.95

Magnum™ Tire Gauge



All Magnum™ gauges come with Dual Bleed buttons for faster setting

Magnum™ Tire Pressure Gauges

- Huge 3-1/2" Glow-in-the-Dark face for high accuracy and the easiest readability
- High flow release button, one piece swivel chuck
- **HOLDS PRESSURE UNTIL RELEASED**
- Internal gauge damper for more consistent, accurate reading
- 17" hose with swivel
- Comes with Silver case

#52001	0-60 by 1/2 lb.....	\$79.50
#52011	0-40 by 1/2 lb.....	\$79.50 NEW
#52021	0-30 by 1/4 lb.....	\$79.50
#52031	0-15 by 1/4 lb	\$79.50

Dual Bleeds on all Magnum™ gauges



Includes Silver carrying case

Deluxe Tire Pressure Gauges

- 2-1/2" Glow-in-the-Dark face for easy readability
- High flow release button and one piece swivel chuck
- **HOLDS PRESSURE UNTIL RELEASED**
- Internal gauge damper for more accurate readings and longer life
- Ultra flexible 17" hose

#52003	0-60 by 1/2 lb.	\$45.95
#52013	0-40 by 1/2 lb.	\$45.95
#52023	0-30 by 1/4 lb.	\$45.95
#52033	0-15 by 1/4 lb. DUAL BLEED.....	\$45.95
#52073	Metric 0-4 BAR by .01 BAR	\$49.95
#52053	0-100 ANGLE chuck.....	\$47.95
#52063	0-100 with 'Foot' valve (see below)	\$49.95

(foot valve is for dual wheels)

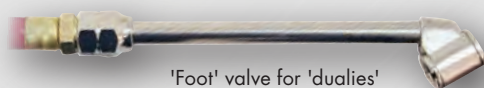

'Foot' valve for 'dualies'



Dual Bleeds (15 psi only)



Keep Your Tire Pressure Constant With TIRELIEFS™

Pro-Team TIRELIEFS™ Kit

- Kit includes: 6 TIRELIEF™ valves, 12 wheel adapters, setting tool, inflation adapter and carrying case

#50100.....\$259.90

Note: TIRELIEFS™ are designed ONLY to relieve normal tire pressure build-up ON THE TRACK. They should not be used as a safety device.



Inflation Adapter



- Use to air up tires when a quick change adapter is installed in the valve stem hole
- Saves drilling a hole in the rim

#50220..... \$11.50

Quick Change Adapter



- Makes quick work of changing or resetting TIRELIEF™
- Unscrew and remove the TIRELIEF™ valve from the rim without losing air pressure
- Aircraft alloy aluminum, low profile
- Installs in 5/8" hole in rim – use factory valve stem hole or drill a new one

#50240 Set of 4\$46.95

Valve Core Stem Tool



- Conveniently stores valve cores in the handle
- Durable aluminum with stainless steel tip
- Includes 3 spare cores

#50270..... \$17.95

TIRELIEFS™ Tire Pressure Relief Valves



- Relieves tire pressure build-up as you race – automatically
- 3-40 psi range
- 100 mesh inlet filter – to keep dirt inside tire from plugging TIRELIEF™
- Lightweight aluminum – only 9 grams – won't affect wheel balance.
- To install drill & tap a 1/8" NPT thread in rim

#50000 Set of 4 \$73.95

TIRELIEF™ Setting Tool



- Lets you set your TIRELIEF™ valves before you install them in the rims
- Uses compressed air to accurately simulate tire pressure

#50290 0-60 psi.....\$44.95

Hi Temp Silicon Valve Stem QC Grommets



- High temp 400° grommets

#50301 Not for use with 50265.....\$6.50

#50008 Replacement TIRELIEF™ "O" rings & quad seals Set of 4 \$10.95

Low Profile Valve Stems



- High temp grommets, low profile

#50265 (Brass) Set of 4 \$16.50

Track Your Tires With Precision

Comes with Silver case AND pouch



NEW for 2015:

Incl. Rubber TEST BLOCK to verify calibration

Tire hardness has a huge affect on your car's performance. A tire too hard won't bite and a tire too soft may wear quickly or even ball up. Also tire hardness changes during its life cycle. To run your best you must keep track of all your tire's hardnesses. These easy-to-use tools will help you do just that - quickly, accurately & easily.

Digital Durometer

NEW Digital Readout (0-100 Shore 'A' scale)

- Straight edge on base to 'rock' durometer for more consistent results
- Non-slip coating for better grip
- Accurate, easy to use

#50547 w. Silver case AND pouch..... **\$99.95**

Dial Tread Depth Gauge

- Reads in 1/32", accurate to 1/128" (that's less than .010")
- Easy to read, easy to use

#50562 w. Silver case **\$23.95**

#50560 w. pouch only **\$21.95**



Deluxe Durometer - Dial Type

Racing tire hardness tester
NEW Design - more accurate

- Reads from 0-100 points (Shore 'A' scale)
- Straight edge on base to 'rock' durometer for more consistent results
- Non-slip coating for better grip
- **Calibration test block included**
- Dial can be 'Zeroed'

#50546 w. Silver case AND pouch..... **\$65.95**



Comes with Silver case AND pouch

Basic Durometer - Dial Type

Racing tire hardness tester - lower cost model

- Reads from 0-100 points
- Dial can be 'Zeroed' (Shore 'A' scale)

#50553 w. red case..... **\$53.95**



Non-Slip Coating Gives You A Better Grip And More Accurate Readings

Comes on most Longacre® durometers and tread depth gauges.



Dial Durometer & Tread Depth Gauge Set

- Includes Silver case

#50556..... **\$82.50**



Digital Durometer Tread Depth Gauge Set

- Includes Silver case

#50557..... **\$114.95**



Special Model For RC Cars

#79980 RC model..... **\$59.95**
(Special calibration for soft RC car tires)





Checking header temps



Infrared Laser Pyrometer

- Instant response, non-contact temps
- To 600° F or °C
- Back light for night use
- Laser sighting for accuracy
- Holds readings longer for easier use

#50612 \$79.95



NEW!

Infrared Laser Pyrometer

- Reads to 1400° F
- Laser sighted
- Back light for night use

#50615 \$139.95



Dual Function Infrared Laser Pyrometer With Tire Probe

- Use as a probe type pyro for tires OR a non-contact IR pyro
- Accurate, fast response in either mode
 - 1400° range on IR, 500° range w. tire probe
 - °F or °C switchable
- Incl. tire probe & new Silver case

#50620 \$219.90



Comes with Silver case

Basic Pyrometer

- Accurate, fast response
- Straight cord tire probe
- 1400° range (w. proper probe)
- °F or °C switchable
- Less carrying case

#50635 Economy model.. \$109.90



Skin Packed

Deluxe Digital Tire Pyrometer

- Accurate, **SUPER-FAST RESPONSE** electronics
- Low battery indicator and auto shut-off
- 2000° Range (tire probe max 500° – see optional brake/surface probe on page 47)
- Coil cord tire probe and carrying case
- °F or °C switchable
- Can hold highest temp reached
- Compares one temp to another with the push of a button

#50640 Pyrometer, tire probe, Silver case \$144.90



Tire Temp Charts

- 2 Tire temps on front, chassis setup sheets on back

#22528 Tire temps – 1 pad of 50 sheets \$9.95

Displays All 12 Temps At The Same Time!

Deluxe Memory Tire Pyrometer

Easy To Use!

- Makes taking temps an easy one person job
- Memory stores 10 complete sets of temps with easy recall
- TIRE TEMPERATURE AVERAGING • Advanced electronics stabilize readings for consistent results
- Takes temps in any order • Built-in night light • Low battery indicator
- Includes carrying case and NEW adjustable tire probe
- Plus built-in 4 car stopwatch w. 75 lap memory (also see "Interval Timing" below right)

Coming Soon!

All new memory pyrometer **on a tablet**

Will display all 12 temps plus memory temps for comparison

See page 13 for a hint



#50690 Memory tire pyrometer (w. adjustable probe).. \$398.90
#50691 Metric °C..... \$398.90



Comes with Silver case



One Valuable Step Beyond Basic Lap Times

In addition to our 4 car built-in stopwatch function you can now get overall lap times plus 3 different segments within that lap. Check corner exit times, straightaway times, or individual corner times – any partial lap segment time you want. Learn where you are fast and where your competition is catching you.

Adjustable Tire Pyrometer Probe

- Adjust the probe depth to your preference or type of tire
- Works with any current or recent Longacre® pyrometer
- 500° max temp.

#50750..... \$104.90



Incl. Adjustable Tip Tire Probe



Standard Tire Probe (not shown)

#50730..... \$68.95
#50740 Brake/surface probe..... \$98.95 (not shown)

Color Tire Temp Charts

See page 46 & 69



Standard Memory Pyrometer

- DISPLAYS 12 TEMPS AT ONCE
- 10 set memory
- Includes coiled cord probe and silver case

#50682..... \$339.90
#50683 Metric °C... \$339.90



NEW! AccuTech® Stepper Motor Gauges

The next generation in instrumentation.



#46540
OP 0-100 psi...\$134.90



#46535
FP 0-15 psi...\$134.90



#46545
WT 100°-280°...\$99.50



#46553
OT 100°-340°...\$99.50



#46555
Volt 8-18 V...\$94.90

Sensors are included with all gauges



'Stepper Motor' Racing Gauges



Stepper motor gauges use a small electronic motor that only turns in tiny fractions of a rotation to drive the pointer. Many professional race teams – **NASCAR®**, etc. – are switching to this style of gauge in all their cars.

See the in-car TV cameras.

- **Built-in Warning Lights** – Ultra Bright 2 stage LED 2 setpoints are easily adjusted to your needs (critical oil press has 3 setpoints). **For example** set water temp for just above normal running temp (if you run 215° set it at 230°). Above that the LED comes on to let you know the motor is starting to get warm. Set the second one at the max temp your engine can tolerate (say 250°). At this point

the LED flashes to attract your attention, possibly saving motor damage.

Since oil pressure is so critical it has 3 set points. You can set the first just below normal running pressure (say normal is 60 psi set it at 50 psi – no damage there). At this point the LED comes on. Set the second at 35 psi. The LED flashes – you need to know here, possible damage. Set the third at 20 psi. Engine damage is likely here. At this third setpoint the LED continues to flash **PLUS the gauge backlight changes color and starts to flash.** It's hard to miss this – day or night. It allows you to get the engine shut down before it blows up, saving you \$\$\$.

- Gauges are **2-5/8"** and have a lightweight molded polycarbonate/ABS case.
- An **electronic sensor** (included) is installed on the motor to drive the gauge – **no oil or fuel in the driver's compartment for safety.**
- **Thru-the-dial LED backlights** and an illuminated pointer make these easy to read at any speed.
- **"Presentation" at turn-on** Gauges go thru a self test. Pointers swing full scale and all LEDs come on.
- **Quick & simple to install.** Connect power wires and ground to your car. Install the sensors on the motor, connect the sensor wire and you're done.



Extra **SMi™** sensors for your spare motors
(sensors are included w. all gauges)

0-100 psi oil or fuel press. #43520\$64.95
100-280° water or oil temp. #43500 ...\$39.95

0-15 psi fuel press #43510 \$64.95
100-340° water or oil temp #43505... \$39.95

All New AccuTech® SPORTSMAN™ Gauges

Quality Built Mechanical Racing Gauges – All NEW for 2015

- Viscous damped pointers for steady readings
- Solid brass CNC machined gears • Sharp looking NEW graphics
- Gauges come complete with back lights, temp manifold fittings and brackets



2014 style gauges available as supply allows.



#46511
Oil Pressure 0-100 psi...\$30.90



#46506
Fuel Pressure 0-15 psi...\$30.90



#46516
Water Temp. 100°-280°...\$41.95



#46521
Oil Temp. 100°-340°...\$41.95



Additional Manifold Fittings For Temp Gauges

For **AccuTech®** (Sportsman™ and SMi) and most other major brands of temp gauges – water & oil

- #46150 1/2" NPT manif. fitting \$8.95 (most common)
- #46160 3/8" NPT manif. fitting..... \$9.95
- #46181 1/4" NPT manif. fitting.....\$10.95

Memory Tach Panels And Tachs

"Stepper Motor" Memory Tachs

What is this? - "Stepper motor" tachs use a small electric motor to drive the pointer. It is more precise than the more common 'aircore' instruments whose accuracy can be affected by the windings. Many professional race teams - **NASCAR**®, etc. - are switching to this style of gauge and tach for the improved accuracy.

SMi™ AccuTech® 4-½" Memory Tach

- **Maximum RPM recall** - Just push the Recall button.
- **High RPM Warning light - 2 stage** - First warning can be set for just over your normal maximum RPM, the second stage at the redline. You get a warning of too many revs before you blow an engine. Can also be used as a 2 stage shift light.
- **LED back light** - Back light shows thru the dial face PLUS the pointer is LED illuminated to make this the easiest tach to read - and super sharp looking too.
- Stepper motor precision tach at an affordable price.

#44384 tach only\$189.00

#44477 tach w. panel..... \$204.90



AccuTech® New Silver Face SMi™ Stepper Motor Memory Tachs

- Much more accurate than traditional 'air core' tachs
- Recalls max RPM with one button
- Hi RPM warning lite to help prevent over-reving expensive motors
- 4-½" LED backlit face

#44381
tach ... \$169.90

DLi™ Data Logging 4" Stepper Motor Tach

What is this? - This DLi™ tach records RPM 10 times every second and plays back the in the paddock - one lap or up to an hour. The super accurate Stepper Motor movement shows you how low the RPM goes in the turns (change gears or downshift?), how quickly RPM goes up on the straight (shiftpoint?), the highest RPM reached, and how the RPM pattern changes as you run more laps. The timer even lets you know where these events happen on the track.

This is valuable information you can't get any other way and will help you improve your car's performance.

This DLi™ tach bridges the gap between basic recall tachs and expensive full data logging systems.



AccuTech® Stepper Motor Data Logging DLi™ Tach

- Records RPM all around the track. Replay in the pits.
- Play-back can be real time, 1/3 speed, or double (to see a full lap quickly).
- You can record multiple sessions - OR - just highest RPM if that's all you need.
- And there's a multi-stage progressive shift lite for precision shift points - OR - a pit road speed indicator.
- The 2 stage High RPM warning lite will help prevent over-reving expensive motors.

The numbers are LED back lit and the pointer is illuminated for easy reading. The 4" dial face is easy to read and the compact case is lightweight and weatherproof.

#44390 Tach only \$298.00

#44479 Tach w. panel \$314.90



AccuTech® Digital Memory Tach



This tach is reasonably water resistant but should be covered or removed before pressure washing car.

- **State-of-the-art electronics give you accuracy to within 10 RPM**
- Ultra light weight - only about 1-½ ozs
- High RPM warning light - helps prevent accidental over revving of expensive motors
- Tach function is self-powered (battery lasts 300+ hours), Optional: connect to car's power for back light and warning light
- Fast response, Easy recall

#44391 0 - 10,000 RPM..... \$199.90

#44402 0 - 19,000 RPM\$219.90

New SPORTSMAN™ Black Aluminum Tach Panels



New SPORTSMAN™ Mechanical Gauges In Black Aluminum Panels w. SMi™ Stepper Motor Memory Tachs

- **Maximum RPM recall** – Just push the Recall button.
- **High RPM Warning light** – Helps prevent over-revving expensive motors.

• **Tach has LED back light** – shows thru the dial face PLUS the pointer is LED illuminated.

• **SPORTSMAN™ gauges** are pre-wired and come with warning lites and all senders.

#44440 2 gauge – OP, WT..... **\$252.95**

#44441 3 gauge – OP, WT, OT..... **\$303.95**

#44443 3 gauge – OP, WT, FP..... **\$303.95**

#44445 4 gauge – OP, WT, OT, FP .. **\$359.95**



Additional Manifold Fittings For Temp Gauges

- For **AccuTech®** (SPORTSMAN™ and SMi) and most other major brands of temp gauges – water & oil
- #46150 1/2" NPT manif. fitting **\$8.95** (most common)
 - #46160 3/8" NPT manif. fitting..... **\$9.95**
 - #46181 1/4" NPT manif. fitting..... **\$10.95**

Steel Braided Gauge Lines

- SS braided Teflon lines
 - Can be removed and replaced over again without breaking or leaking
- #45020 24"..... **\$19.95**
 - #45030 36"..... **\$24.95**
 - #45040 48"..... **\$27.95**
 - #45050 60"..... **\$31.95**



New SPORTSMAN™ Black Aluminum Panels

New SPORTSMAN™ Mechanical Gauges In Black Aluminum Panels

- Gauges have sharp looking new graphics for 2015.
- Gauges have viscous-damped pointers for steady readings.
- Gauge mechanism uses solid brass CNC machined gears.
- Panels are pre-wired, ready to install, and have all senders.

- #44430 2 gauge – OP, WT \$102.95
- #44431 3 gauge – OP, WT, OT \$158.95
- #44433 3 gauge – OP, WT, FP \$158.95
- #44435 4 gauge – OP, WT, OT, FP \$203.95

Wiring is premium fine strand with high temp silicone insulation, soldered and heat shrink terminals.



You can mount these using bolt-on brackets – see page 54.

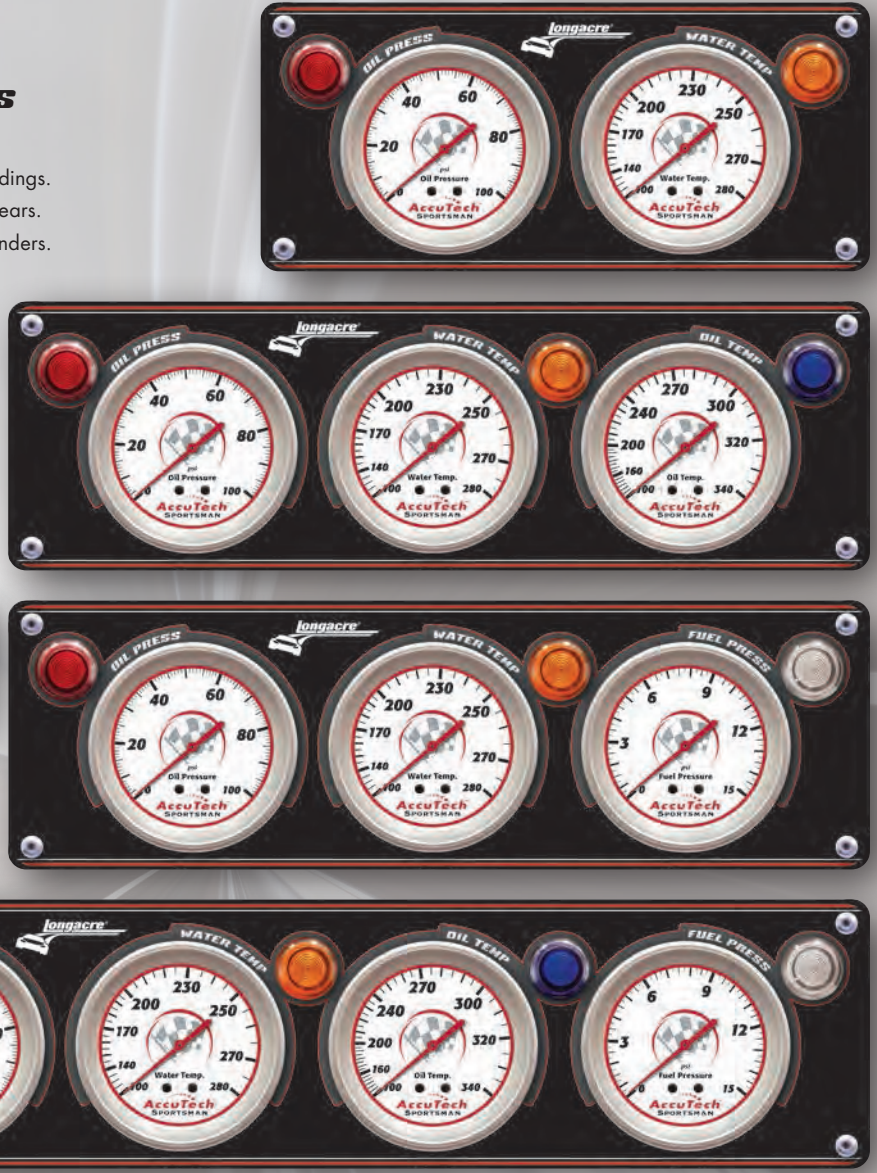

New Econo Black Aluminum Panel

- SPORTSMAN™ mech. gauges (see style above)
- Pre-wired with OP warning light only

#44429 2 gauge – OP, WT \$89.90

Sprint Car Panel (Designed To Stay W. Motor)

- Ultra lightweight weather resistant aluminum gauges and genuine carbon fiber panel
- Incl. mag kill switch & low oil pressure warning light (9 volt battery powered)
- Mounts from engine side of firewall, attach with Dzus fasteners – OR – permanently mount

#44423
\$198.00



GAUGES, TAGHS, PANELS & ELECTRICAL

New SMi™ Black Aluminum Tach Panels

New SMi™ Stepper Motor Gauges In Black Aluminum Panels W. SMi™ Stepper Motor Memory Tachs

- All gauges and tachs have multi-stage built-in warning lites – easily set by user.
- Electronic sensors mount on motor – no fuel or hot oil in driver's compartment.
- Pre-wired, includes all sensors, ready to install.
- All gauges and tachs are LED back lit for best viewability.

#44470 2 gauge –
OP, WT \$424.90

#44471 3 gauge –
OP, WT, OT \$525.90

#44473 3 gauge –
OP, WT, FP-15 PSI....\$545.90

#44475 4 gauge –
OP, WT, OT, FP-15 PSI ..\$619.90



Additional Manifold Spare Motor Fittings For Temp Gauges

For **AccuTech®** (SPORTSMAN™ and SMi) and most other major brands of temp gauges – water & oil

#46150 1/2" NPT manif. fitting \$8.95 (most common)

#46160 3/8" NPT manif. fitting.....\$9.95

#46181 1/4" NPT manif. fitting.....\$10.95



Extra SMi™ sensors for your spare motor

(sensors are included w. all panels)

#43520 0-100 psi oil or fuel press..... \$64.95

#43510 0-15 psi fuel press.....\$64.95

#43500 100-280° water or oil temp.... \$39.95

#43505 100-340° water or oil temp. ..\$39.95



New SMi™ Black Aluminum Panels



New SMi™ Stepper Motor Gauges In Black Aluminum Panels

- Gauges have built-in multi-stage warning lites – set to your preference.
- Numbers and pointer are LED back lit for easy viewing, day or night.
- Panels are completely wired, ready to install. Just connect 4 wires to your car.
- All sensors incl. – mount on the motor – no fuel or hot oil in driver's compartment.



- #44460 2 gauge – OP, WT \$244.90
- #44461 3 gauge – OP, WT, OT \$345.90
- #44463 3 gauge – OP, WT, FP-15 PSI \$375.90
- #44465 3 gauge – OP, WT, FP-100 PSI \$375.90
- #44467 4 gauge – OP, WT, OT, FP-15 PSI \$479.90

Pre wired – ready to install. Saves time and hassle.



Extra SMi™ sensors for your spare motors

(sensors are included w. all panels)



- #43520 0-100 psi oil or fuel press..... \$64.95
- #43510 0-15 psi fuel press..... \$64.95
- #43500 100-280° water or oil temp... \$39.95
- #43505 100-340° water or oil temp... \$39.95

You can mount these using bolt-on brackets – see page 54.



Scott Bloomquist



Brake Pressure Panels And Gauges



(not back lit)

Mini Brake Balance - Black Aluminum Panel - Liquid Filled

- Panel includes (2) 1½" 1500 psi gauges and fittings with bleeders

#44124.....\$73.90

Brake Balance Black Aluminum Panel - Full Size Liquid Filled

- See exactly what your balance is

- Panel includes (2) 2½" 1500 psi gauges & fittings with bleeders



(not back lit)

#44134
\$80.90

Sprint Car Panel (Designed To Stay W. Motor)

- Ultra lightweight weather resistant aluminum gauges and genuine carbon fiber panel
- Includes mag kill switch and low oil pressure warning light (9 volt battery powered)
- Mounts from engine side of firewall, attach with Dzus fasteners – OR – permanently mount

#44423
\$198.00

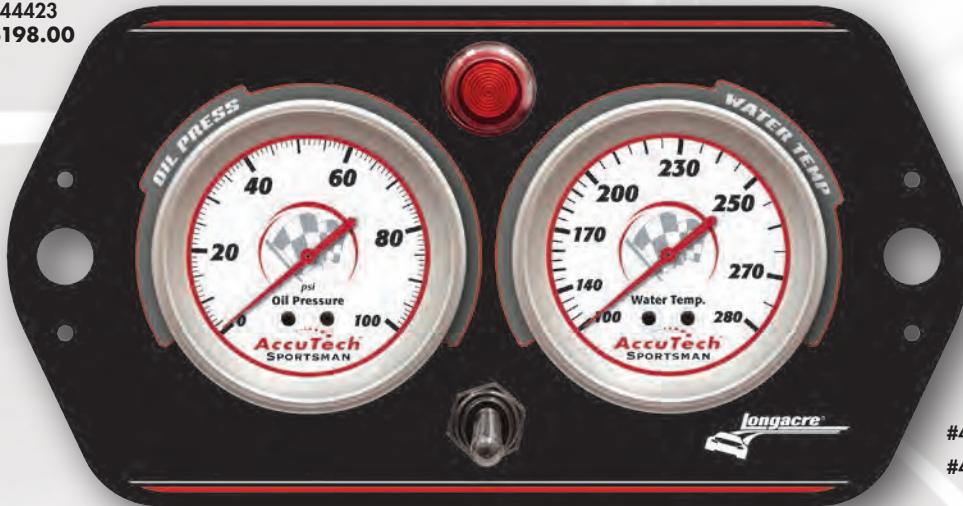

Lightweight aluminum gauges w. 48" temp cable



#46512 Oil pressure..... \$44.90

#46517 Water temp (48" cable).... \$59.90

(see pg 61 for Low Oil Press kit)

Block Fittings For OP And FP Gauges

#45240 1/8" NPT to #4 AN straight Oil Pressure Block Fitting.....\$4.50

#45230 1/8" NPT to #4 AN 90° Oil Pressure Block Fitting.....\$5.95



#45240

#45230



Steel Braided Gauge Lines

- SS braided Teflon lines
- Can be removed and replaced over again without breaking or leaking

#45020 24" w. block fitting.....\$19.95

#45030 36" w. block fitting.....\$24.95

#45040 48" w. block fitting.....\$27.95

#45050 60" w. block fitting.....\$31.95



Heavy Duty Wiring Harness

- Plugs into all Longacre switch panels
- Color coded wires match Longacre dash panels
- Saves time, hassle and confusion

#44930.....\$29.90

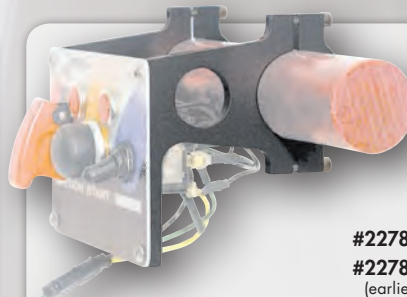

Bolt-On Switch Panel Mounting Brackets

- Mount your switch panel quickly & easily
- Includes 2 brackets

#22783 1¾" bar – universal.... \$40.90

#22787 1½" bar – universal.... \$40.90
(earlier panels may require minor modification)

New Black Aluminum Switch Panels

All our switch panels use HD 40 amp ignition switches, HD start buttons, and high capacity wire with soldered & heat-shrunk terminals. They are pre-wired and ready to install.

Many of these switch panels include a replacement weatherproof switch cover if you prefer that style. Easy to change.

You can mount these using bolt-on brackets – see page 54.



Start/Ign. Panel

#44861 \$33.90

Start/Ign. Panel W. Flip-Up Safety Cover & Pilot Light

#44863 \$43.90

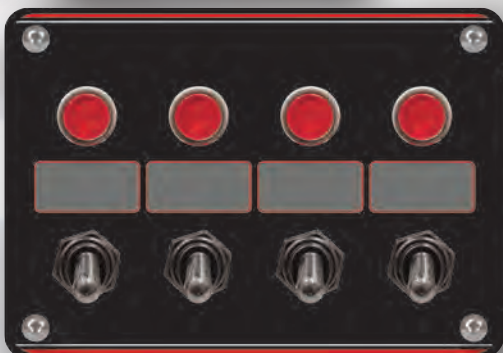

Panel W. 4 Accessory Switches & Pilot Lights

#44865 \$54.90



Start/Ign. Panel W. Flip-Up Safety Cover, 2 Accessory Switches & Pilot Lights

#44867 \$65.90

Start/Ign. Panel W. Flip-Up Safety Cover, 4 Accessory Switches & Pilot Lights

#44869 \$84.90



Start/Ign./Master Disconn. Panel W. Flip-Up Safety Cover & Pilot Light

#44871 \$91.90

Battery Disconn. Panel

#45760
Switch 2 Post
\$33.50

#45784
Switch 4 Post Altn
\$34.50



GENUINE

Carbon Fiber Switch Panels

- High capacity 40 amp switches (at 12 volts) with rubber switch boots to seal out moisture
- Red safety flip-up switch covers
- High insulation wiring with soldered terminals



#44510 Ignition switch & start button \$49.95



#44535 Ignition switch & start button + two accessory switches w. pilot lights \$72.95

2014 Models - Available While Supplies Last

Switch Panels W. Silicone Rubber Weatherproof Switch Covers - To Keep Out Dirt And Moisture



Switch Panel w/o Pilot Light
#44801 \$33.90



Switch Panel W. Pilot Light
#44831 \$37.90



Start/ign. Accessory Switch Panel W. Pilot Lights
#44881 \$59.90



Accessory Switch Panel
#44751 \$54.90



#44661 Standard Panel w. Pilot Lights \$57.90

Standard Panel W. One Accessory Switch



#44671 Standard Panel w/o Pilot Light \$52.90



Standard Panel
#44601 \$38.90



Standard Panel W. Pilot Light
#44611 \$42.90



Panel W. Flip-Up Safety Cover & Pilot Light
#44623.. \$42.90



Panel W. WP Switch Covers & Pilot Light
#44621.. \$37.90



#44891 \$59.90

Start/ign. Accessory Switch Panel W. Pilot Lights
#44893 \$64.90



Start/ign. Panel W. Blank Space
#44899 ... \$47.90

Start/ign. Panel W. Battery Disconn.
#44897 \$69.90



Start/ign. Panel W. 6 Accessory Switches
#44895 \$79.90

Start/ign. Panel W. 2 Accessory Switches Plus Battery Disconn.
#44898 \$89.90



2014 Models - Available While Supplies Last

Liquid Filled Brake Balance Panels



Full Size Brake Balance Panel

#44138 (molded cf) ... \$80.90

Mini Brake Balance Panel

#44128 (molded cf) ... \$73.90



Full Size Brake Balance Panel

#44136 (aluminum) \$80.90

Mini Brake Balance Panel

#44126 (aluminum).... \$73.90



Panels W. SMi™ Stepper Motor Memory Tachs



Molded CF Panels

#44482 2 gauge - OP, WT Tach \$255.95

#44484 3 gauge - OP, WT, OT Tach \$306.95



#44486 3 gauge - OP, WT, FP Tach \$306.95

#44488 4 gauge - OP, WT, OT, FP Tach \$359.95



Aluminum Panels

#44452 2 gauge - OP, WT Tach \$255.95

#44454 3 gauge - OP, WT, OT Tach \$306.95



#44456 3 gauge - OP, WT, FP Tach \$306.95

#44458 4 gauge - OP, WT, OT, FP Tach \$359.95



Panels W. SPORTSMAN™ Gauges



Molded CF Panels

#44462 2 gauge - OP, WT \$106.95

#44464 3 gauge - OP, WT, OT \$162.95

#44466 3 gauge - OP, WT, FP \$162.95

#44468 4 gauge - OP, WT, OT, FP.. \$208.95



Aluminum Panels

#44412 2 gauge - OP, WT \$106.95

#44414 3 gauge - OP, WT, OT \$162.95

#44416 3 gauge - OP, WT, FP \$162.95

#44418 4 gauge - OP, WT, OT, FP.. \$208.95



Carbon Fiber Panels

#44422 2 gauge - OP, WT \$154.90

#44424 3 gauge - OP, WT, OT \$219.90

#44426 3 gauge - OP, WT, FP \$219.90

#44428 4 gauge - OP, WT, OT, FP.. \$274.90



Gauge Panels W. AutoMeter® Gauges



Ultra-Lite™ Gauge Panels

#44222 2 gauge - OP, WT \$234.95

#44224 3 gauge - OP, WT, OT \$368.95

#44226 3 gauge - OP, WT FP \$345.95

#44228 4 gauge - OP, WT, OT, FP \$469.95

Sport Comp™ Gauge Panels

#44302 2 gauge - OP, WT \$204.95

#44304 3 gauge - OP, WT, OT \$314.95

#44306 3 gauge - OP, WT FP \$284.95

#44308 4 gauge - OP, WT, OT, FP \$389.95



Heavy Duty 40 Amp Switches (at 12 volts)

- Silver plated contacts
- Solid brass mechanisms
- Tough phenolic bodies



Ignition Switch

- With Silicone rubber weatherproof switch cover and 2 terminals

- #45420 Switch, cover, terminals..... \$11.50
- #45423 Weatherproof switch \$19.95
- #45430 3 terminal switch \$14.90
- #45462 Momentary toggle START..... \$13.50

Ignition/Start Switch Combination

1 Switch Does It All

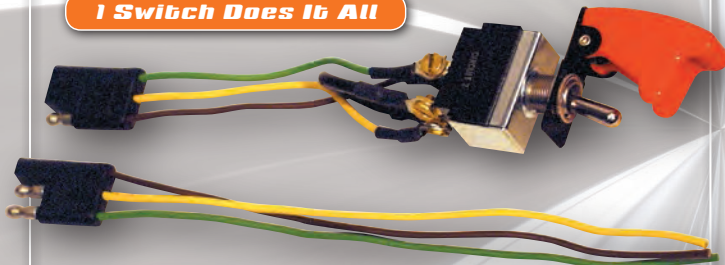

- **DOWN** is off • **MIDDLE** is Ignition On • **UP** is momentary start
- Pre-wired with color coded harness and flip-up switch cover

#45490..... \$34.90

Heavy Duty Starter Solenoid Kit W. Firewall Starter Button

- High capacity extra heavy duty metal cased solenoid, wiring harness, remote starter button
- Remote start button is great for setting valves, etc.

- #45800 Complete kit \$40.90
- #45900 Solenoid only..... \$26.90



Ignition Switch W. Flip-Up Cover

- Shut off quickly in an emergency – like a stuck throttle
- Prevents accidental turn on of ignition

#45470 HD switch, safety cover, terminals..... \$18.95

Starter Button

- Weatherproof rubber cover and 2 terminals



- #45460 Push button \$10.50
- #45462 Momentary TOGGLE START switch (below – w. cover).... \$13.50

Replacement Switch Covers

- #45300 Black Weatherproof cover..... \$4.95
- #45370 Red Flip-up safety cover..... \$10.95



Magneto Switch

- 2 circuits that kill mag and shut-off accessories
- Weatherproof cover

#45440 Switch and cover \$24.90



Tim Sims Nesmith



Anodized Panels W. Battery Disconnect Switches

- Battery disconnect switches with a bright red handle
- Easier to find in an emergency
- Prevents battery drain
- 175 Amp Continuous Rating, 6-36 volt, 1000 Amps peak alternator circuit 20 amps (except #45782 at right - 125 amps)

#45784 4 term. for cars with or without alternator in aluminum panel (alternator circuit 20 amps)	\$34.50
#45760 2 term. for cars without alternator in aluminum panel	\$33.50



#45750 2 term. for cars without alternator (switch only)	\$27.90
#45780 4 term. for cars with or without alternator - switch only (alternator circuit 20 amps)	\$29.90
#45749 2 term. Push-Pull (switch only)	\$24.95
Shut off entire electrical system in an emergency with a quick 'hit'.	
#45748 Economy Battery Disconnect Switch (switch only)	\$15.95
#45782 4 terminal, extra hi capacity - Alternator circuit carries 125 amps, battery circuit 175 amps cont. (switch only)	\$69.95
(needed for cars using very high capacity alternators)	

Weatherproof Switches - Sealed With A Tough Polymer Coating



The back side of these switches are sealed with a tough, waterproof polymer coating to keep out dirt, dust, & moisture that can turn a critical switch into junk & put you out of a race.

Low cost insurance - no annual premiums.



(Weatherproof Switch Covers Incl. On 45423 & 45466.)

#45423 HD 40 amp ignition switch	\$19.95
#45466 Starter button	\$18.95
#45753 Battery disconnect 2 terminal	\$47.95
#45788 Battery disconnect 4 terminal	\$49.95
#45789 Extra hi capacity battery disconnect 4 terminal	\$84.95
<small>(see 45782 above)</small>	

Battery Jumper Posts

- Makes it easier to jump start or charge the battery
- Color coded protective boot

#45720 Red, positive	\$16.95
#45740 Black, negative	\$16.95



Battery Cable Ends

#45660	\$4.75
--------------	--------



Battery Thru Panel

- For safely running battery cable thru your firewall
- Prevents shorts

#45700	\$11.90
--------------	---------



Universal Battery Terminal

#45680	\$8.95
--------------	--------



Weather Pack Connector Kits

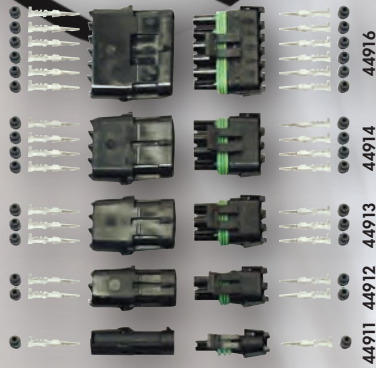

- Wire like the Pro's
- Seals out dirt and water
- Everything you need is included, plus an extra pin just in case

#44911 1 pin	\$6.95	#44914 4 pin	\$10.95	#44919 Weather Pack Replacement M/F Pins & Seals (10 each).....	\$8.95
#44912 2 pin	\$7.95	#44916 6 pin	\$12.95		
#44913 3 pin	\$8.95	#44920 Cavity Plugs (10) ea.....	\$7.45		



Weather Pack Crimp Tool With Crimp Dies

- Use with Weather Pack connector kits
- Ratchet style crimper insures a positive connection
- Fast and easy

#44905 \$102.95



Pin Extraction Tool

- Required for safe removal of pins from Weather Pack housing

#44909 \$9.95

Rear Battery Cable Kit

- Ends are factory soldered – and include an extra terminal just in case you need to change the length
- Kit includes high amp battery cable, end terminals, color coded terminal boots to prevent arcing, Firebraid™ insulation, firewall grommet, Adel™ clamps & wire ties



- The longer your battery cables are, the heavier gauge they need to be

#48050 13' 1/0 cable, battery behind diff.....	\$99.95
#48000 10' #2 cable, battery behind driver	\$67.95

Deluxe Battery Cable Kit

- Includes solenoid and battery disconnect switch
- Ends are factory soldered for quick, simple installation
- Includes ground cable and all cables from battery to switch
- Starter cable heat protected with Firebraid™



#48115 \$164.95



Universal Battery Terminal

#45680 \$8.95



110V Flange Mount Connection

- Great for dry sump oil heaters

#45662..... \$25.95

Heavy Duty Ground Strap

- Braided – 14" long – to complete the installation

#48110 \$16.95



Adel™ Line Clamps

- High temperature neoprene lining, makes a neat and safe installation
- Keeps lines and wiring where they belong



16 Gauge Heavy Duty 'Fab' Wire W. Hi Temp Silicone Insulation

- This is premium fine stranded wire w. thick hi temp insulation
- 15 ft rolls in 4 colors to color code

#44956 Red.....	\$12.95	#44957 Black.....	\$12.95
#44959 Yellow	\$12.95	#44958 Orange.....	\$12.95



#47000 3/16" ID steel brake lines	Pack of 10	\$7.50
#47050	Box of 100	\$49.90
#47100 5/16" ID #4 AN lines	Pack of 10	\$8.95
#47150	Box of 100	\$61.95
#47200 9/16" ID fuel line	Pack of 10	\$9.85
#47250	Box of 100	\$68.95
#47300 13/16" ID #8 AN line	Pack of 10	\$10.75
#47350	Box of 100	\$74.85
#47400 15/16" ID #10 & 12 lines	Pack of 10	\$12.90
#47450	Box of 100	\$78.85
#47500 1-3/16" ID #16 AN lines	Pack of 10	\$17.50

GAGELITES™ Engine Warning Light Systems

• Kit includes sender, light, wire, terminals

<u>Oil Pressure</u>		<u>Complete Kit</u>		<u>Sender Only</u>
20 psi OP	1/8" NPT	#40000.....	\$21.90	#43080..... \$15.95
15-50 psi OP	1/8" NPT	#40100.....	\$31.95	#43000..... \$23.95
<u>Water Temperature</u>				
230° WT	1/2" NPT	#40150.....	\$22.95	#43250..... \$16.95
230° WT	3/8" NPT	#40152.....	\$24.95	#43252..... \$21.90
250° WT	1/2" NPT		#43300..... \$23.95
<u>Oil Temperature</u>				
270° OT	1/2" NPT	#40350.....	\$27.50	#43350..... \$19.90
300° OT	3/8" NPT	#40400.....	\$29.50	#43400..... \$19.95
<u>Fuel Pressure</u>				
2-7 psi adj. FP	1/8" NPT	#40250.....	\$30.95	#43020..... \$21.95
4 psi FP	1/8" NPT	#40251.....	\$24.95	#43021..... \$14.95



Water Pressure Warning Light Kit

Light comes on if you have sudden loss of coolant pressure.

- Alerts you to a punctured radiator or burst hose, helps prevent expensive engine damage

#40141	\$24.95
#43241 (sender only).....	\$18.95



Sprint Car

Low Oil Pressure Warning Lite Kit

For Cars Without Batteries

- Includes holder for lightweight 9V battery (not incl.), low oil pressure switch (20 psi), warning lite, heavy duty mag kill switch w. weatherproof switch cover, wire & terminals

#45624 Kit w. weatherproof switch	\$39.95
(see page 59 for switch details)	



Replacement Light Assemblies

New Brighter Design Same As On Panels - (install in 3/4" Hole)

#41801 Clear	\$9.95
#41802 Red.....	\$9.95
#41803 Amber.....	\$9.95
#41804 Green.....	\$9.95
#41805 Blue.....	\$9.95

Switch Panel Pilot Light Replacement

#42300 12V Red (not shown).....	\$8.30
---------------------------------	--------

Low Oil Pressure Ignition Or Electric Fuel Pump Shutoff Switch

- Switch shuts off the ignition or electric fuel pump when oil pressure drops below 12 psi
- Helps prevent engine damage or fire and keeps the motor from starting until the oil pressure is up
- Should be used with momentary bypass switch for starting



#43600	\$26.95
#45462 Momentary bypass switch	\$13.50

NEW!



Digital Air Density Gauge

Keep Your Motor Running At Its Peak Horsepower

- Accurate **electronic Air Density** measurement with easy-to-read digital display
- Shows your **baseline** so you don't forget.
- A **red LED** flashes to let you know if you need to change jets (air density has changed)
- Also displays current **temp** and **barometric pressure**

#50887..... **\$198.00**

Air density or RAD (relative air density) is used as a valuable tuning tool to keep your jetting at its optimum.

To use this gauge get a box of spark plugs and work on your jetting, reading the plugs as you go. When you get the motor just where you want it, record the air density.

Later – this could be later today, tomorrow, next week, or next month – if the air density changes – and it will – you will instantly know how much to re-jet to keep that peak performance.

A good rule-of-thumb for a Holley carb is one jet size for each 3% change in air density.



Analog (Dial Type) Air Density Gauge

#50888..... **\$124.90**

Comes w. Silver case



Coil Over Wrench Billet Aluminum

- Billet aluminum keeps coilovers undamaged
- Replaceable stainless steel pin
- Comfortable handle with rounded edges makes adjustments easy

#22589..... **\$39.90**

Longacre Track Mat



NEW!

Thicker Padding For More Comfort

Other track mats use foam that is too soft (it's cheaper!) and a vinyl covering that won't stand up to years of use (it's cheaper too!!!). Longacre's Track Mat is more comfortable to use and will last and last.

- Makes work under the car comfortable (if not fun!)
- Folds up for easy storage, thick vinyl for durability
- Dirt and oil resistant for quick clean-up

#11175 **\$26.95**

#11180 Set of 2 track mats **\$46.95**

Oil Filter Cutter

Billet Aluminum

Cut your old filter open to spot problems before they cost you an engine



- Billet anodized aluminum, ball bearings
- CUTS SMALLER FILTERS TOO – from 2 3/8" – 5" in diameter

#77750..... **\$66.95**

Dial-Type Engine Leak-Down Tester



- Easy-to-use tester checks ring seal, valves, even head gaskets
 - Quickly tell – from the outside – when your engine needs an overhaul
- #73010 \$104.90
 #73012 14mm replacement hose for Leak Down Tester..... \$26.95

Digital Leak-Down Tester



**Don't wait too long to rebuild that expensive motor
 But don't do it too soon either.**

- Much more accurate than traditional testers. Reads critical leak-down to .5% (1/2 of 1%)
 - Gauges have back lites for easy readability and low batt. indicators
 - 14 mm spark plug connector and hose included
 - Control inlet valve avoids shock to gauges when air is turned on, allowing more accurate readings, easier use, and longer gauge life
- #73014 incl. Silver carrying case..... \$199.90



Digital Shock Inflators



Easy to read, quick & easy to use with controlled flow valves.



Includes Silver carrying case

NEW – 300 psi Digital gauge, easily reads to .5 psi

EXCLUSIVE Feature:
 Controlled flow inlet and bleed valves makes precision shock settings much easier.

- Special chuck prevents pressure loss and inaccurate settings
- Extra long hose makes filling shocks on car a snap
- Fill and bleed quickly and accurately
- Inlet valve prevents air contamination when not in use, connect directly to nitrogen line

#50473 0-300 psi (above) \$174.90

Basic Digital Shock Inflator

- Reads to 300 psi by .5 psi units
 - Special chuck prevents pressure loss
- #50483
 Digital Shock Inflator... \$139.90



Basic Dial Model Shock Inflator

- Compact, dial gauge reads to 300 psi by 5 psi, easy to use
- #50493 Basic Shock Inflator \$89.95





Comes with Silver case



AccuLevel™ Digital Level Pro Model

- Back light for dark places under car
- Measure suspension & spoiler angles, lots more
- Incl. Silver case • Reads to .1° (1/10°) – from 0 to 90°
- Simple to use, easy to read, accurate
- Can be field calibrated to maintain accuracy
- Used in our Digital Caster/Camber gauges

#78311 AccuLevel™ digital level.....\$119.90



AccuLevel™ Digital Level - Basic Model

- Measure suspension and spoiler angles, lots more • Reads to .1° (1/10°) – from 0 to 90°
- Simple to use, easy to read, accurate • Can be field calibrated to maintain accuracy

#78310 AccuLevel™ digital level..... \$89.95



Digital Caliper

Here's a really handy must-have tool. Accurately measure all sorts of things around the shop.

Measure drill bits, bolts, sheet metal & tubing wall thickness, caster camber & bump steer shims, lots more.

- A precision machinist's tool with all sorts of handy uses around the shop
- Reads by .0005", accurate to .001, 0.0 to 6.000"
- Large easy-to-read digital display
- Auto-off saves battery life, comes on automatically, doesn't need to be re-zeroed each time you use it
- Includes padded case

#73007.....\$34.95



Analog Style Angle Finder

- Liquid Filled • Ball bearing pivot
- Bind free at any angle
- Use for front & rear suspension, etc.

#50815..... \$64.95



Safety Wire

- .032 stainless steel wire

#22599.... \$18.95



Plumb Bob Kit

- Square rear end
- Lots of other uses

#50820..... \$17.50



Safety Wire Pliers

- Insures parts stay on your car
- Quickly and neatly twists wire
- A must for all high vibration locations

#22598..... \$32.95



Hot Sleeve

- Protects arms from burns while working around engine
- Made of durable, heat-resistant Kevlar®
- Will work on either right or left arm • Sleeve is washable

#11230 \$19.95



Longacre Pit Gloves

- Help protect your hands from injury & burns
- Velcro™ wrist strap for snug fit
- Synthetic leather palm and fingers for a good feel Breathable top for comfort

#11206 Small..... \$19.95 #11209 X-Large..... \$19.95
 #11207 Medium..... \$19.95 #11210 XX-Large \$19.95
 #11208 Large..... \$19.95



Cordless Pit Impact Gun

Save Time & Hassle

Cordless Pit Impact Gun

Plenty of power to pop off lug nuts with 24 volts.
True portability, no air hose to trip over

New Features:

- **330 lbs. ft. of torque**, 1/2" drive
- Variable speed trigger
- LED Worklight
- Battery charge indicator
- Includes, battery(s), Fast Charger, & case



#68604
Gun, 2 batteries, Fast charger, case



#68602
Gun, 1 battery, charger, case



#68604 Impact gun w. <u>2</u> batteries & Fast charger.....	\$289.90
#68602 Impact gun w. <u>1</u> batt. & Fast charger	\$249.90
#68611 Set of <u>2</u> guns w. <u>3</u> batteries & Fast charger.....	\$439.90
#68618 Spare battery	\$79.90
#68620 Replacement Fast charger.....	\$49.90
#M68620 International 220V Fast charger	\$69.90

Cordless Pit Impact Gun Sockets

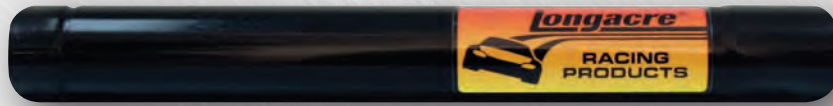

12" Long Lug Nut Socket - For Deep Wheels

- Impact grade
- 6 point design is **easier on lug nuts**
- Spring pops out lug nuts

#68528 Extended impact socket..... \$49.95

Lug Nut Sockets - Impact Grade

- Tough impact sockets designed to instantly kick out the lug nuts on ultra fast pit stops
- #68525 & 68526 are CNC machined from SAE 4340 alloy billet & double heat treated for severe service

#68526 Deep impact socket \$58.95

#68525 Short impact socket \$52.95

#68524 6 point deep impact socket..... \$15.95
(designed for regular use in pits, spring pops out nuts)



Aluminum Spokes With Smooth Grip

These wheels have a high grip polyurethane coating.

- #56801 15" Black - Smooth grip - dished (2.75") \$53.50
- #56803 15" Blue - Smooth grip - dished (2.75")..... \$53.50
- #56805 15" Red - Smooth grip - dished (2.75") \$53.50
- #56811 17" Black - Smooth grip - dished (2.75") \$53.95
- #56813 17" Blue - Smooth grip - dished (2.75")..... \$44.45*
- #56815 17" Red - Smooth grip - dished (2.75") \$44.45*

(*special close-out pricing on 56813 & 56815 - limited supply)

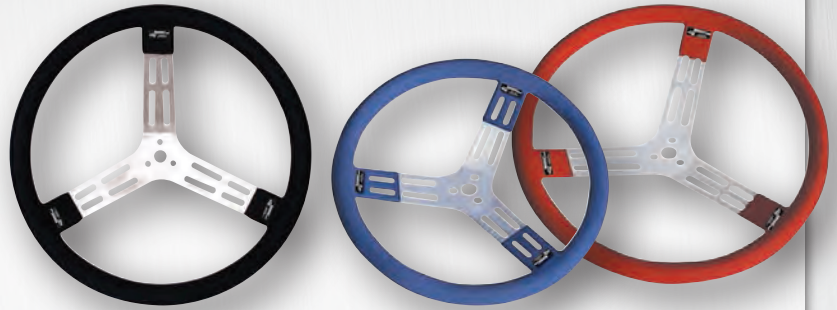

"Fat" Grip Aluminum Wheel

- Thicker rim for a better grip and less wrist and arm strain - ideal size for long races
- 15" dished aluminum wheel

- #56809 15" Black - Smooth grip - dished 2.75" \$69.95



Bump Grip Aluminum Spokes

- #56820 15" Black w. bumps - dished - 2.75" \$66.95
- #56825 17" Black w. bumps - dished - 2.75" \$66.95

New Suede Wrapped Steering Wheel

Sports car and open wheel road race



Where steel wheels are required. Some upper NASCAR® divisions require steel with no holes in spokes



Steel Wheels

- #56841 15" Black Smooth grip - dished - 2.75" \$44.95
- #56851 17" Black Smooth grip - dished - 2.75" \$46.95

- Better grip and cushioning for improved steering control and comfort, ergonomic molded grips on rim
- Premium quality hand sewn with CNC machined aluminum center

- #56911 290 mm flat - 3 hole (5mm & different pattern) \$159.00
- #56913 320 mm flat - 3 hole (5mm & different pattern) \$159.00
- #56906 290 mm flat - blank \$159.00
- #56908 320 mm flat - blank \$159.00

Precision Fit Splined Hub For Better Steering Control - SFI™ Approved

(for suede wheels AT LEFT ONLY - these have a different mounting pattern see pg 68 for others)

Sports Car/road race:

Yellow release ring per FIA™, SFI™ approved 5 mm 3 bolt pattern

- #56610 \$119.90



Kart Steering Wheels

- 13" or 14" diameter
- Lightweight aluminum
- 14" wheels are uncoated and shot peened for good grip

- #56830 13" Black dished - 2.75" \$49.95
- #56834 Ultra light 14" Uncoated Aluminum - shot peened.. \$52.90
- #56835 Ultra light 14" Drilled DRILLED Uncoated Aluminum \$74.90



Suede Wheel For Karts

- Suede gives good grip to reduce arm & wrist strain
- These are flat - not dished - and have std. 3 bolt mounting

- #56826 11.5" \$89.90
- #56829 13" \$89.90

NEW!

Pro Aluminum Wheels W. Suede Wrapped Rim

Suede gives an excellent grip for reduced wrist and arm strain during the race.



This style of wheel is being used by many NASCAR® teams

- 15" w. 2.5" dish
- Std. 3 and 6 hole mounting
- Center is anodized with beveled edges

#56800 \$149.90
 (Some of NASCAR® upper divisions require steel wheels with no holes in spokes.)

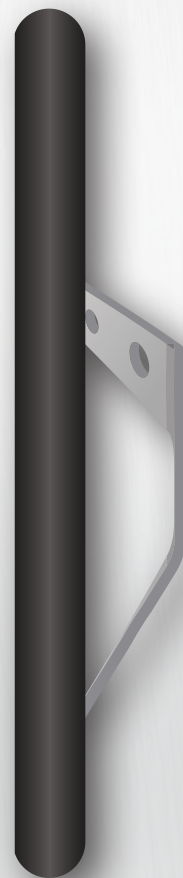

Race Car Steering Wheels

Ultra Lightweight Drilled Uncoated Aluminum Wheels

**184 Holes
CNC Drilled
To Save
Weight
Count Them!**



drilled
on 2
sides

smooth

- #56838 15" Uncoated BLACK - DRILLED - DISHED (2.5").... \$79.90
- #56837 15" Uncoated ALUM. - DRILLED - DISHED (2.5").... \$74.90
- #56867 15" Uncoated BLACK - DRILLED - FLAT..... \$79.90
- #56866 15" Uncoated ALUM. - DRILLED - FLAT..... \$74.90
- #56833 14" Uncoated BLACK - DRILLED - DISHED (2.5") ... \$74.90
- #56835 14" Uncoated ALUM. - DRILLED - DISHED (2.5") ... \$74.90
- #56836 15" Uncoated aluminum - smooth - dished (2.5")... \$52.90
- #56822 15" Uncoated aluminum w. BUMPS - dished (2.5") ... \$62.90
- #56834 14" Uncoated aluminum - smooth - dished (2.5") .. \$52.90

NEW!

These Drilled Wheels Are 1/2 The Weight Of Others

- These are drilled on 2 sides for additional weight savings (others brands are usually drilled only on 1 side).
- Shot-peened rim for good grip.
- Holes give even better grip.

Steering Wheel Accessories

All Hubs And Spuds Include A Second Safety Groove For Your Protection.

Precision Fit Splined QD Hub For Better Steering Control

Any play in the steering – including the hub – takes away control from the driver, letting the car 'wander around'. This Pro hub has a **precision machined 4130 spud** and a **T6 Hard Anodized** splined hub for a super tight fit, yet is easy to remove and install.

Plus, there are multiple sets of mounting holes so you can 'clock' your wheel 3 times closer.

For safety there are 2 sets of retaining grooves. If you don't get the ring engaged it will catch on the second safety groove rather than come off on the track. The steel spuds can be installed on both 3/4" and 5/8" shafts.

Splined hub – pull ring release with double safety grooves on weld-on SAE 4130 spud

#56605 for 3/4" or 5/8" shaft.....\$69.90



Sprint Car:
Precision Splined hub & tapered spud for **KSE™** steering boxes (same hub as above)

#56603....\$89.95



for 3/4" or 5/8" shaft

Steering Quick Disconnects

- Hex type
- Weld to 3/4" or 5/8" (karts) steering shafts
- Aluminum hub
- Double safety grooves

#56600 Hex hub – push button release.....\$29.95

Precision Fit Splined Hub For Better Steering Control – SFI™ Approved

(for Sports Car & Road Race suede wheels only – different mount)

Any play in the steering – including the hub – takes away control from the driver, letting the car 'wander around'. This QD release has a **precision machined 4130 spud** and a **T6 Hard Anodized** splined hub for a super tight fit, yet is easy to remove and install. Plus, there are multiple sets of mounting holes, so you can 'clock' your wheel three times closer.

For safety there are two sets of retaining grooves, If you don't get the ring engaged, it will catch on the second safety groove rather than come off on the track.

The steel 'spuds' can be installed on 3/4", 5/8", or 1.0" shafts.

Splined hub – pull ring release with double safety grooves on weld-on SAE 4130 spud.

Sports Car/road race:
Yellow release ring per FIA™, SFI™ approved. 5 mm 3 bolt pattern

#56610.....\$119.90



(for 5 mm 3 bolt pattern only)

Steering Wheel Spacer

Billet aluminum

#56703 3/4"\$13.95

(To shorten your steering shaft so you can get out of the car easier use 2 or more of these spacers.)



Steering Wheel Alignment Indicator

- Put your steering wheel on exactly the same way each time
- Bolts under steering wheel and onto the shaft

#56700 for 3/4" shaft\$43.95

#56700 for 1-1/8" shaft.....\$43.95

Steering Wheel Hook

- Hang your wheel out of the way
- Bolts on – no welding

#22576 1 3/4"\$15.95

#22577 1 1/2"\$15.95



Nose Pad

- Required by most rules
- Medium density, similar to ProTecto™ roll bar padding

#56899.....\$16.95



Hi Density Steering Wheel Nose Pad

- Triangular shape improves safety and visibility of dash – see your gauges more easily
- Uses material similar to our Hi Density roll bar padding for better protection

#56890.....\$25.95



Stopwatch Clipboards

- Lightweight aluminum, won't break like plastic can
- Powder coat finish with edge protectors
- Rubber feet prevent sliding and protect car's finish
- Professional color lap charts included with practice times on back

2 Watch Economy Clipboard W. Robic™ SC 505 Watches

- Times every lap, counts laps, has 5 lap memory

#22324 With Robic™ SC 505.....\$106.95

Clipboards W. Robic™ SC 606 Watches

- These watches clock every lap, show average MPH, and have a 50 lap dual memory

#22319 With 1 Robic™ SC 606.....\$77.95 #22321 With 2 Robic™ SC 606...\$119.95

Clipboards W. Robic™ SC 848 Watches

- These deluxe watches clock every lap, show average MPH, have a 300 lap memory, a backlit 3 line display, and show total run time.

#22328 With 1 Robic™ SC 848.. \$106.95 #22330 With 2 Robic™ SC 848...\$176.95



Padded Storage Pouch

- Black vinyl outside, foam padding inside
- Keeps clipboard and stopwatches clean and safe – a good investment

#22390.....\$21.95

Without watches

Clipboard Only

#22314.....\$37.95
For "W" series Robic™ watches

Lap Times/Chassis Sheets

- Lap times, practice times on back
- Chassis setup sheets, tire temps on back
- Punched for 3 ring binder
- 2 sided – get added use

#22525 Lap times – 1 pad/50 sheets ... \$9.95

#22528 Chassis setup – 1 pad/50 sheets\$9.95



GPS Coming Soon!

HOT LAP™ Lti In-Car Lap Timer



- 200 Lap Memory with easy recall
- Lap count shown on display
- Standard transmitter range 100-120 feet
- Backlight for night use is standard
- Displays difference between current lap and last lap AND current lap and fastest lap
- Red LED flashes when current lap time is the fastest
- Display runs on internal battery. Timing is not connected to the car's electronics to avoid "noise." (Backlight uses car's power for illumination only.)

#21710 Complete System\$289.90
#21712 Display & receiver (less Transmitter).....\$192.90
#21716 Transmitter only.....\$122.95
#21720 Jumper to use 12V external battery.....\$12.95 (optional)

Stopwatches

Longacre® Memory Stopwatch

- Lap counter
- Crisp one-button action
- 30 lap memory
- Comes with Silver case

#22164.....\$34.90

#22162 w/o case\$29.95



Robic™ SC 606

- Clocks every lap
- Computes avg. MPH
- Counts laps to 999
- 50 lap memory

#22172.....\$42.95



Robic™ SC 848

- 300 lap memory
- Backlight display
- Calculates average MPH
- 3 line display
- Counts laps to 999
- Shows total run time

#22175.....\$65.95



Robic™ SC 505

- Time every lap plus automatic lap count
- 12 Memory recall
- One button action for simple timing

#22168.....\$31.95



Roll Bar Padding

ProTecto 180™ Medium Density Roll Bar Padding New 180° Design Plus Lower Price



Color	Each
#65692 Black	\$2.95
#65694 Blue	\$2.95
#65696 Red.....	\$2.95

Ships more efficiently too – Costs less to ship a 20 piece case than 12 of old ProTecto™. Save some money!

Don't pad the back of your roll bars.

- Easier to install – use wire ties or tape
- For 1-3/8" to 1-3/4" bars
- 1-1/8" thick at top x 36"



NEW!



Roll Bar Padding Kits

All the padding needed to do most cars – in a convenient package. You get a combination of Hi Density full size padding for around your head, Mini HD padding for posts where line-of-sight is important, and **New ProTecto 180™** for arm and leg protection.

Kit includes: 2) Full size Hi Density pad 2) Mini Hi Density 4) **NEW ProTecto 180™**

Separate prices total \$62 – save money

#65135 Black..... \$54.95

Trailer Hitch Bumper



Ouch

Save your knees and shins!

Low cost insurance – no annual premiums



- Uses material similar to our Hi Density roll bar padding for good protection
- Easy to install without removing the ball – takes less than 1 minute
- Held on with wire ties (included)
- Doesn't interfere with normal trailer use
- Fits most hitches with no modification (many others w. only slight modification)

#65885.....\$14.95



Door Bar Padding Mat

- Protect your left elbow, arm, hand and wrist
- Made from fire resistant padding similar to our High Density roll bar padding but slightly softer
- Saves you tons of time – no need to cut and fit several separate pieces
- Mounts quickly with adjustable molded-in straps
- Sharp looking too with a clean appearance & rounded edges
- 39.5" x 16 .5" x 1" thick

#65130 \$89.95

**High Density Roll Bar Padding
In Regular And New "Mini" Size**



"Mini" padding

Regular size

All Longacre® HD padding is "pre taped" with adhesive to make installation easier.

- Provides maximum in energy absorption and flame retardation
- Will not drip or melt in fire • Fits bars for 1-1/2" to 1-3/4"
- Self-adhesive (pre-taped) for a quick and clean installation
- Used by many Sprint Cup™ and Nationwide Series™ teams
- "Mini" padding has a streamlined shape to focus padding where you need it, improve sightlines and reduce blind spots. Plus it's lightweight with a sporty appearance.

#65162	Reg. Size – Black	\$13.95
#65166	Reg. Size – Red	\$13.95
#65164	Reg. Size – Blue	\$13.95
#65182	"MINI" – Black	\$12.95
#65184	"MINI" – Red	\$12.95
#65183	"MINI" – Blue	\$12.95



**"SFI" Approved Roll Bar Padding
Meets The New Tougher "SFI" Standard**

- Provides maximum in energy absorption and flame retardation, will not drip or melt in a fire
- Required in NHRA®, SCCA®, recommended in NASCAR®
- Meets new SFI spec 45.1 • Pre-taped for easy installation
- Fits bars 1-1/2" to 1-3/4" x 36" length

#65169 Black.....\$20.95



COMING SOON!
"SFI" approved Mini padding (see above)

Bolt - On Accessories - No Welding

Adjustable Brackets Mount At Multiple Angles -
Easier To Install!

Drink Holder

- Large capacity insulated bottle with tube
- Includes "bite valve" to avoid leaks from tube
- Bolts onto your roll bar - no welding required
- Powder coated with anodized bracket

#22551 1 $\frac{3}{4}$ " bar.. \$60.95

#22553 1 $\frac{1}{2}$ " bar.. \$60.95



Replacement Bite Valve

#22559..... \$8.45

Smaller Size Radio Box For Newer Radios

#22560 1 $\frac{3}{4}$ " bar..... \$44.95

#22562 1 $\frac{1}{2}$ " bar..... \$44.95

Padded to protect your valuable radio



Coming Soon:

2 new radio holders. One is a pouch that protects your radio better and can be mounted almost anywhere. The second is a universal holder with a Velcro™ strap.

Large Radio Box

- Bolts onto the roll bar
- Protects your valuable radio

#22561 1 $\frac{3}{4}$ " bar..\$59.95

#22563 1 $\frac{1}{2}$ " bar..\$59.95



Bolt-On Switch Panel Mounting Brackets

- Mount your switch panel quickly and easily
- Includes 2 brackets

#22783 1 $\frac{3}{4}$ " bar - universal.....\$40.90

#22787 1 $\frac{1}{2}$ " bar - universal.....\$40.90

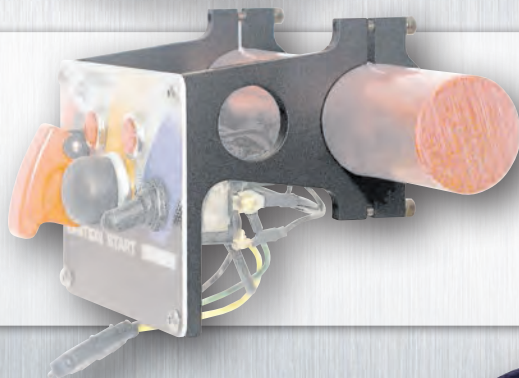

Helmet Hook

- Protect your helmet
- Bolts onto roll bar - no welding
- Lightweight billet aluminum, black anodized

#22570 1 $\frac{3}{4}$ " bar..... \$15.95

#22572 1 $\frac{1}{2}$ " bar..... \$15.95

COMING SOON: A new safer helmet hook. Flexible in a crash.



Penske® Shock Reservoir Bracket

- Quick, easy, neat mounting
- Thicker - only 1 bracket needed
- Prevents reservoir distortion
- Lightweight billet aluminum

#22764 1 $\frac{3}{4}$ " bar..... \$39.95



Universal Bracket

- Mount mirror, switch panel, etc.
- Lightweight aluminum

#22755 1 $\frac{3}{4}$ " bar short.....\$17.95

#22757 1 $\frac{1}{2}$ " bar short.....\$17.95



Quick And Easy Installation

Won't Vibrate Loose

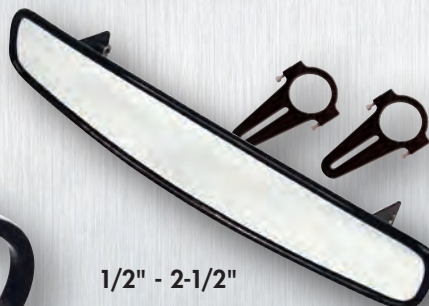

1/2" - 2-1/2"

Wide Angle Mirror Kits

14" Mirror Kit

with 1/2" - 2 1/2" Range Bolt-On Brackets

#22534 1 3/4" \$59.95 #22535 1 1/2" bar \$59.95

14" Mirror Kit

with 2" - 5 1/2" Range Bolt-On Brackets

#22536 1 3/4" \$59.95 #22537 1 1/2" bar \$59.95

17" Mirror Kit

with 1/2" - 2 1/2" Range Bolt-On Brackets

#22530 1 3/4" \$69.95 #22531 1 1/2" bar \$69.95

17" Mirror Kit

with 2" - 5 1/2" Range Bolt-On Brackets

#22532 1 3/4" \$69.95 #22533 1 1/2" bar \$69.95

Mirror Only

#22544 14" \$26.50

#22547 17" \$34.75

Brackets Only

- No welding – bolts to your roll bars
- Brackets CNC machined from billet aluminum

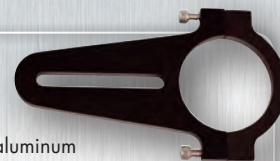

#22538 1/2" to 2 1/2" for 1 3/4" bar \$38.95/pair

#22539 1/2" to 2 1/2" for 1 1/2" bar \$38.95/pair

#22540 2" to 5 1/2" for 1 3/4" bar \$39.95/pair

#22541 2" to 5 1/2" for 1 1/2" bar \$39.95/pair



New design bracket for 2014:
More adjustment, easier to install.

3-3/4" Spot Mirror - Bolts On

- Mounts on driver's or passenger's side
- Adjusts easily
- Bolts in place solidly

#22548 3 3/4" Spot Mirror for 1 3/4" bar \$44.95

#22549 3 3/4" Spot Mirror for 1 1/2" bar \$44.95

#22550 3 3/4" Replacement Spot Mirror for 22548/49 \$24.95



Billet Rear End Breather Kit

- Includes vent, hardware and hose for a complete installation
- Quick, professional, won't leak
- Clamp-on design

#22568 1 3/4" bar \$40.95

#22569 1 1/2" bar \$40.95

Billet Rear End Breather

- No welding required

#22564 1 3/4" \$29.95

#22566 1 1/2" \$29.95





Complete Brake Line Kit

- Includes 4) SS braided lines to go from the chassis to the wheels, an assortment of pre-flared bendable steel chassis lines, fittings, connectors, frame tabs, Adel™ clamps and wire ties
- Enough parts to do almost any car from a midget to a Sprint Cup car (order caliper fittings separately)

#45215 #3 AN \$149.95
 #45216 #4 AN \$149.95

NOTE: NOT For Street Driven Cars. Min. Bending Radius 2"

Caliper Fitting

- 1/8" NPT, #3 or #4 AN
- Fits most popular models

#45240 #4 st..... \$4.50
 #45230 #4 90°.....\$5.95
 #45243 #3 st.....\$3.90
 #45233 #3 90°..... \$6.25

• 7/16"-20 #4 AN 90° (fits GM single piston)
 #45250..... \$4.95



Long Leg Caliper Fitting

- 1/8" NPT 90° with #4 and long leg for extra clearance

#45220 #4 \$6.95

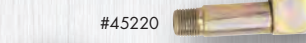

Brake Line Frame Tab And Fittings

- #3 or 4 AN x 3/16" brake line, "bulkhead" style with jam nut for easy mounting
- CNC machined from lightweight aluminum

#45263 #3 Fitting only \$9.95
 #45273 #4 Fitting only \$9.95
 #45283 Frame tab only \$2.90
 #45286 #3 fitting & tab.....\$12.95
 #45288 #4 fitting & tab.....\$12.95

Brake Balance Adjusters

Deluxe Billet Aluminum Brake Balance Adjuster

- Frictionless Polymer bearing mount – for easy, no-bind adjustments
- Detents every 90° make precise adjustments easier. "Click" the exact change you want.
- NEW HD braided flex connector – shorter, won't 'wrap up'
- 3/8" – 24 or 7/16" – 20 connector to your bias bar

#44108 3/8" – 24 (Wilwood™).....\$69.95 #44109 7/16" – 20 (Tilton™) \$69.95

Basic Brake Balance Adjuster

- Friction free, no alignment bind
- Easy turn knob for quick adjustments at speed
- NEW HD non-twisting flex connector – won't wrap up

#44107 3/8" – 24 (Wilwood™, others).....\$45.95

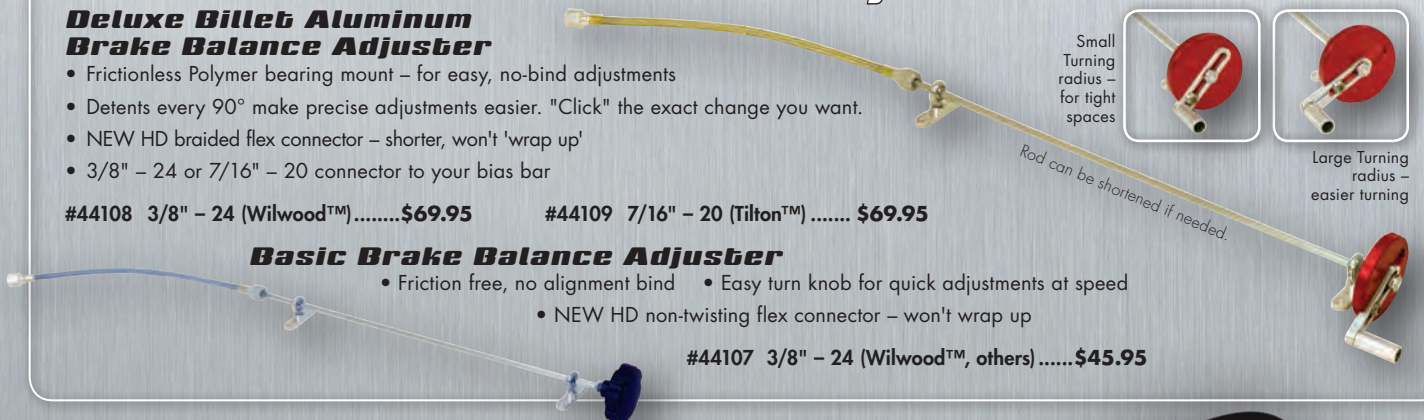

Small Turning radius – for tight spaces

Large Turning radius – easier turning

Rod can be shortened if needed.



Steel Braided Brake Lines

- Stainless steel braided teflon line with permanently swaged fittings
- 2500 psi working pressure

AN Fittings Both Ends

#45120 16" #4AN.....\$13.95 #45150 22" #4AN\$14.70
 #45123 16" #3AN.....\$13.95 #45153 22" #3AN.....\$14.70
 #45140 18" #4AN..... \$14.30 #45160 24" #4AN\$14.95
 #45143 18" #3AN..... \$14.30 #45163 24" #3AN.....\$14.95

NOTE: NOT For Street Driven Cars. Minimum Bending Radius 2"

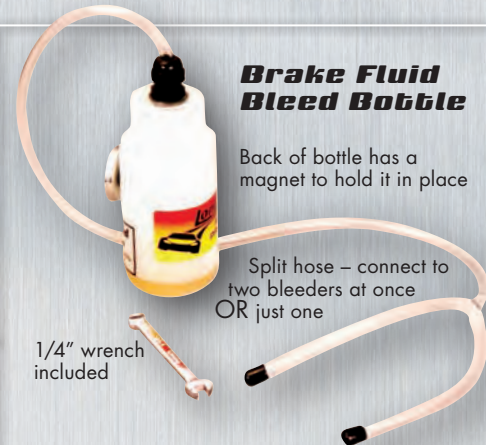

Brake Fluid Bleed Bottle

Back of bottle has a magnet to hold it in place

Split hose – connect to two bleeders at once OR just one

1/4" wrench included

- Magnet holds bottle while you bleed your brakes – no more spilled fluid
- Hoses connect to bleeder valves – bleed one at a time or both at once
- Cap for hoses prevents leakage during storage
- Comes with 1/4" bleeder fitting wrench

#45200 (2 bottles)\$33.90
 #45202 (1 bottle).....\$19.95

Engine Hardware



Throttle Stop Bracket

- Helps prevent broken throttle arms with a positive stop
- Lightweight aluminum, won't change in use

#32730 Holley® 4 bl... \$35.95
 #32732 Holley® 2 bl... \$37.95



Carb Bushings

#32707 Split bushing... \$5.95 for Holley® carbs



Carb Linkage Kit

- Includes 2 all metal rod ends, aircraft aluminum tube, Holley® carb bushing, 2 return springs, bolts and nuts
- Just bend to clear air cleaner, cut to length, thread one end (requires 1/4-28 tap)
- Easily forms to any car or use straight
- 6061 T6 Heat treated aluminum alloy is tough to bend but stays to shape in use, won't straighten out and cut throttle travel, costing you precious horsepower.

#32700 23 1/4" \$33.95
 #32702 28 1/2" (longer rod - if needed) \$36.95



Throttle Return Spring Bracket Kits

- Lightweight aluminum bracket, 2 springs, Holley® carb bushing and miscellaneous hardware
- Only fits small block Chevy

#32710 Short - for low or tall air cleaners... \$23.90



Replacement Throttle Return Spring

#32500 Pack of 2.... \$6.95



Deluxe Carb Linkage Kit

- All the parts you need in one handy kit
- Heat treated aluminum tube once formed won't straighten out and cut throttle travel
- Use straight or formed to clear air cleaner (requires 1/4-28 tap)
- Includes 2 all metal rod ends, 6061 T6 aircraft aluminum tube, Holley® carb bushing, 2 return springs & bracket, bolts and nuts and adjustable throttle stop
- Anodized red lightweight aluminum
- Only fits small block Chevy

#32720..... \$79.95

Aluminum Air Cleaner Stud Kit

- Includes aluminum stud & thumb knob, air cleaner lid mounting stop & jam nut
- Mounting stop & jam nut go under air cleaner lid so you can tighten the thumb knob without distorting the lid
- Set screw in thumb knob keeps it from coming loose - beats duct tape!
- Built-in rubber seal keeps dust out of your engine
- Top thread 5/16", bottom carb thread 1/4" or 5/16"

#32750 5/16" carb thread - Holley® \$30.90
 #32752 1/4" carb thread - other \$30.90
 #32754 Replacement Thumb Knob \$12.95



Billet Remote Starter Button

- Crank your motor over from the engine compartment
- Cool Billet aluminum

#45795 ..\$29.95



Spark Plug Viewer

- Get your jetting right for maximum power
- 10X magnification • Incl. SPARK PLUG HOLDER (#50886)
- Comes w. batteries – ready to use

#50886..... \$39.95

#50884 Plug viewer only... \$29.95

#50885 Plug holder only... \$10.95

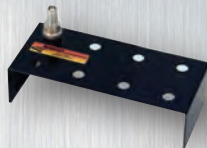

Welding Bosses For Hood Pins

#23625 1/2"-20 (6)..... \$6.95

#23650 3/8"-24 (6) \$6.95

Torsion Clip Hood Pin Replacements

#23550 Pack of 2..... \$3.95



Universal Air Tool Quick Disconnect

- Connects to all 3 commonly used fittings
- No more switching fittings to use that new or borrowed tool

#36013 (pair) \$9.95



Works with all these of these popular disconnects (not incl.)

Engine Compression Tester

- Easy-to-use
- 14 mm plug adapter
- Check for bent or leaking valves, bad ring seal, even leaking head gaskets

#73025 0-300 psi.....\$39.95



12 Point Header Bolts

- Compact 12 point head – use a 3/8" box wrench to tighten around big tubes
- Grade 9 alloy steel
- 170,000 psi

#35600 SB Chevy \$11.90



Hydraulic Clutch Line Kit

- SS braided line quickly and easily connects the clutch master cylinder to the slave cylinder
- Comes complete with fittings for most applications

#28050..... \$33.50



Longacre Radiator Caps

#75260 22-24 psi..... \$11.95

#75265 29-31 psi.....\$16.50



Magnetic Drain Plugs

- Traps ferrous particles and keeps them from damaging your equipment
- Check often to spot developing problems

#33300 1/2" – 20 oil pan \$6.95

#33320 3/8" NPT..... \$6.95



← Plug traps metal particles

Braided Teflon Fuel Line From Cell To Pump

- Best possible fuel flow – no motor lean out
- Smooth bore #8 AN 1/2" Teflon fuel line won't collapse at high fuel draw
- Ends installed, ready-to-use
- Saves time and hassle

#33900 144" length \$109.90
(for 102-114" wheelbase cars)



Lightweight Aluminum Hood Pin Kits

- Includes pins, jam nuts, scuff plates and flip style safety pins

#23500 1/2"-20 – Set of 2.....\$9.95

#23502 1/2"-20 – Set of 6... \$27.95

#23510 3/8"-24 – Set of 2.....\$9.95



New Design Spoiler Supports

- Lightweight T6 aluminum tube w. R & L threads
- Can also be used for windshield supports
- 6", 8", & 10" in polished silver and black anodized tubes
- Incl. both flat top and button head mounting screws

#23756 6" Black.....	\$19.95
#23757 6" Polished.....	\$19.95
#23758 8" Black.....	\$19.95
#23759 8" Polished.....	\$19.95
#23760 10" Black.....	\$20.95
#23761 10" Polished.....	\$20.95

(Length shown is the rod. Heim joints add 1" overall, pivot center-to-center. Adjustment is + 1-1/2" beyond this. For example a 6" support will be center-to-center min 7", max 8-1/2")



Backing washers CNC turned Billet Aluminum Black anodized or polished
Pack of 4 \$13.95 (see below)

Fender Support Kit

- Two flexible supports made from lightweight break resistant polymer material
- Springs back to shape if bent
- Includes all hardware for a quick and professional installation



Adjustable style fender support bracket comes with #23740



• Lightweight aluminum mounts

#23720	Cut rod to length..	\$35.95/pr
#23740	Adjustable length ..	\$41.95/pr
#23744	Replacement rods for 23720/40.....	\$18.95/pr

Steel Hood Pin Kit

#23600 3/8-24..... \$11.95

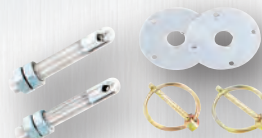

NEW!

Billet Aluminum Shifter Balls

New smaller 1-5/8" ball

NEW design for even better heat insulation. Don't burn your hand late in the race!

- **2" ball:** Extra holes are drilled and mounted with a stainless steel bolt (SS transfers heat poorly) OR on shifter arm stud. Cooler shifting!
- NO INSERT to come out; ball won't come off in your hand during the race
- One piece CNC machined billet aluminum

#22601 3/8"-16 - 2" dia	\$39.90
#22607 3/8"-16 - 1-5/8" dia.....	\$29.95

(both will mount directly to shifter arm stud)

Shifter Arm

- CNC machined billet aluminum
- Lightweight yet strong
- To replace heavier steel original
- Slotted bottom hole to install easier

#22613 Shifter stick 3" **OFFSET**..... \$62.90

Shifter Boot With Quick Access Mounting Plate

- Fire and grease resistant material
- High temperature liner seals out the heat
- Removes in seconds for quick transmission changes

#22615..... \$99.95

Spoiler Supports Ultra Light Weight All Aluminum

(2014 style)

- CNC machined billet aluminum, black anodized
- High strength, lightweight tapered tube
- Bolts on easily and uses specially built aluminum Heim joints to adjust for any angle



#23705 5" support.....	\$25.50
#23706 6" support.....	\$25.50
#23708 8" support.....	\$26.50

(Length shown is the rod. Heim joints add 1" overall, pivot center-to-center. Adjustment is + 1-1/2" beyond this. 6" support will be center-to-center min 7", max 8-1/2")

Backing Disk For Spoiler Support

- Use to support Lexan® spoiler or use to fasten spoiler to deck lid

#23702 Black - Pack of 4.....	\$13.95
#23703 Polished - Pack of 4 ..	\$13.95



CNC turned Billet Aluminum Black anodized

Protect Yourself And Your Car With Insulation

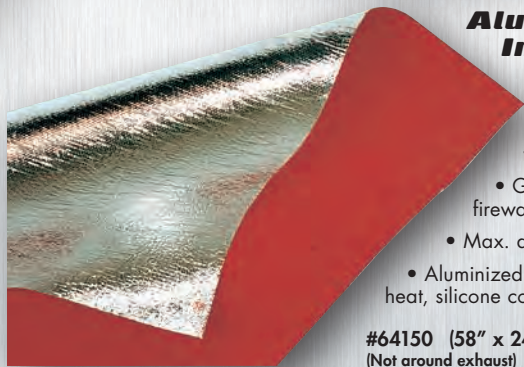

Aluminized Insulation Cloth

- Easy to work with, just cut shape with scissors
 - Good insulation for firewall, floor, tunnel
 - Max. ambient temp: 600° F
 - Aluminized on one side to reflect heat, silicone coated on the other
- #64150 (58" x 24").....\$63.95
(Not around exhaust)

Header Insulation 'Tape'

- Contains exhaust heat for better velocity, scavenging and more power – plus cooler under hood temps
 - 2" x 100' roll will do for most V8 headers
 - Maximum temp: 1,250° F
- #64850 100' x 2" 1/16" thick ...\$66.50
 #64870 50' x 2" 1/16" thick\$37.50
 #64830 50' x 2" 1/32" thick.....\$37.50
 #64880 25' x 2" 1/16" thick.....\$24.50
 #64835 10' x 2" 1/32" thick\$14.45

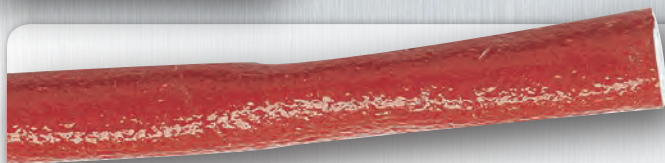

Firebraided Sleeving

- High temp, flexible insulating sleeving
- Silicon coated fiberglass braid keeps headers from burning wires
- Plug wires, battery cables, insulates fuel and oil lines, will not burn
- Maximum temp: 500° F

- #49500 5/16" ID X 36"\$14.90 Plug wires, steel brake lines
- #49520 10' Length\$39.75
- #49600 3/8" ID X 36"\$16.30 Special for 8mm plug wire
- #49620 10' Length\$43.50
- #49700 9/16" ID X 36"\$17.40 Battery cables, fuel lines
- #49720 10' Length\$46.40
- #49750 11/16" ID X 36"\$21.50 #6 fuel line, battery cables
- #49770 10' Length\$57.35
- #49800 13/16" ID X 36"\$23.60 #8 & #10 oil & fuel lines
- #49820 10' Length\$62.95
- #49850 15/16" ID X 36"\$25.90 #12 oil lines, cooler lines
- #49870 10' Length\$68.95
- #49900 1-1/8" ID X 36"\$29.70 #16 dry sump oil lines
- #49920 10' Length\$79.20

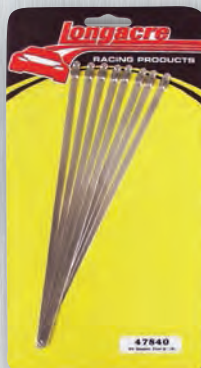

Stainless Steel Ties For Header Tape, Etc.

- Holds header insulation in place
- Heat resistant
- Stays tight
- Use as a super strong wire tie
- Max. temp: 1,250° F

- #47840 8" (8 ties)\$14.45
 #47843 8" (12 ties)\$19.95
 #47846 8" (24 ties)\$36.95
 #47842 14" (4 ties).....\$10.45
 #47845 14" (12 ties)\$27.50
 #47848 14" (24 ties).....\$51.95

Lexan™ Cleaner And Polish

- #1 Cleaner removes dirt and leaves a glaze that cuts static and repels dust
- #2 Polish to remove fine scratches and haze – works GREAT for polishing car paint too, removes oxide & scuffs
- #3 for deeper scratches



- #63500 #1 cleaner\$7.95
 #63600 #2 polish\$8.95
 #63700 #3 polish\$9.95

Try the #2 (red bottle) for polishing your street or show car. The very fine polish removes minor scratches and scuffs and leaves a beautiful mirror finish – without removing excessive paint like rubbing compound can.



Insulating Floor Mats

- Specially designed for use in driver's compartment
- Made from fireproof non-asbestos heavy weight cloth
- Silicon coated on one side and aluminized for heat reflection on the other side
- In the middle is a heavy duty high temp insulation material

• Maximum temp: 600° F

• Eyelets in the corners to mount with rivets or screws

- #64320 24" x 18"\$59.95 #64400 24" x 10"\$49.50
 #64360 18" x 18"\$54.95 #64420 12" x 8"\$28.95



Black Twill Hat

#11655\$9.95



Longacre Pit Gear Bag

- Heavy duty nylon construction
- 25" x 12" x 12"

#11911\$29.95

Car Covers - Custom Built For Race Cars

Race Car Cover

- Heat reflective silver color
- Soft liner won't scratch paint
 - Moisture resistant
 - Zippered window to get in and out
 - Will fit most Late Model cars - All Pro, ASA, & SW Series, etc.
- Eyelets along bottom to secure cover from tampering

#11150 \$179.95

Dirt Late Model Race Car Cover

- Custom designed for Dirt Late Model Race cars with all the same benefits as our race car cover to the left
- Hood zipper allows engine work without removing cover

#11152 \$224.90

Open Wheel Modified Car Cover Great For IMCA, UMP Type Cars!

- Custom designed for Open Wheel Modified cars with all the same benefits as our race car cover above

#11154 \$194.90

Cockpit Car Cover

- Quick & easy to use
- Keeps windows and cockpit free of rain & dust
 - Eyelets along bottom to secure cover
 - Storage bag included
 - Soft liner won't scratch windows or paint

#11156 \$79.95

Silver Cases

Keep everything in order - at the track or around the shop - with our sturdy cases

- Matches all our other Silver cases
- Store parts neatly, not rolling around in your tool box
- Radios, rivets, drills, stopwatches, tire gauges, durometer, etc.

Sizes are approximate and are subject to minor changes.

A 72292	16" x 11 ⁵ / ₈ " x 15"	\$199.95	H 50513	6 ⁵ / ₈ " x 2 ¹ / ₄ " x 1 ¹ / ₂ "	\$14.95
B 50522	16 ³ / ₄ " x 13 ¹ / ₂ " x 4"	\$66.95	I 50511	4 ¹ / ₈ " x 2 ⁵ / ₈ " x 1"	\$11.95
C 50515	14 ³ / ₈ " x 11 x 3 ¹ / ₂ "	\$59.95	79019	22 ¹ / ₂ " x 20 ¹ / ₂ " x 4" ...	\$74.95
D 50518	9 ¹ / ₂ " x 7" x 2"	\$15.95	72280	12 ¹ / ₂ " x 12 x 12 ¹ / ₂ " ..	\$185.00
E 50514	10 ³ / ₈ " x 6 ³ / ₈ " x 3 ³ / ₄ " ...	\$16.95	50520	5" x 4" x 2 ³ / ₄ "	\$14.95
F 50512	8 ¹ / ₄ " x 4 ¹ / ₈ " x 3"	\$14.95	50517	2 ³ / ₄ " x 2 ¹ / ₈ " x 1"	\$9.95
G 50516	9 ¹ / ₂ " x 3 ¹ / ₂ " x 1 ¹ / ₂ "	\$15.95		(not shown)	



16892 146th Street SE, Monroe WA 98272
Phone: 1.800.423.3110/1.360.453.2030
Fax: 1.360.453.2031
www.longacracing.com



Ordering Information

■ When ordering by phone or mail please give:

- 1) Part numbers if possible, complete description, and quantity.
- 2) Your name and complete shipping address
(UPS cannot ship to a P.O. box)
- 3) Payment information such as COD, credit card, etc...

■ Your parts will normally be sent by UPS ground

Delivery time is one to five days, depending on distance. One, two and three-day UPS air services and Parcel Post are also available at a reasonable cost. Priority Mail or Parcel Post may lower cost on one- or two-lb shipments.

■ Parts sent COD will come "Cashier's Check or Money Order"

UPS no longer accepts cash. Get the exact amount when ordering.

■ Orders will most often be shipped within 24 hours - usually the same day

■ When your package arrives, examine it carefully before signing.

If there is any damage, have the driver note it and file a claim with the carrier.

Return policy:

Parts may only be returned with prior permission. Please call first for an RMA (return merchandise authorization). Only new parts may be returned and may be subject to a 20% restocking charge plus a repackaging fee if needed. No returns after 30 days. Customs or special orders cannot be returned. No credit, exchange, or refund on any part that has been used, altered or changed in any way.

Repairs:

We will be happy to repair almost any product we make, regardless of age. But **please consider the total cost:** freight to us, the cost of the actual repair, and the freight back to you – plus your inconvenience of a trip to UPS or the post office. **We don't want you to spend as much on a repair as a new one would cost!**

Our minimum repair charge is **\$18** for non-electronic products and **\$45** for electronic products (scales, etc.) and, depending on the time required, can easily be more. Repair time is 1-5 days plus shipping time.

We sincerely want you to be happy with our products and our service. If you have any questions please call first. Of course **any repair under warranty is done at no charge.**

Limited Warranty Information:

All parts are guaranteed to be free from defects in material and workmanship for a period of one year from date of purchase. After inspection, parts returned pre-paid to the factory with original invoice, required as proof of purchase and date, will be repaired or replaced at our option and returned by UPS ground pre-paid. If you need the parts returned by air service, we may ask that you pay the difference. Parts returned without the original invoice or proof of purchase will be repaired at normal cost. This warranty does not include incidental labor, damage to other parts, or personal injury. No warranty of fitness for a particular application is made due to the nature of auto racing.

Warranty does NOT include damage due to misuse, neglect, abuse or modifications.